

OUR SOLUTIONS ENSURING CLEAN WATER



COLLECTION | PRE-TREATMENT | TREATMENT | PUMPING | REGULATION | STORAGE | RECOVERY





COLLECTION & ACCESS

EFFICIENT FLOOR EQUIPMENT

- INDUSTRIES • SHOPPING CENTRES • TERTIARY • SPORTS COMPLEXES
- FOOD SERVICE • BATHROOMS • PUBLIC SPACES

Gutters

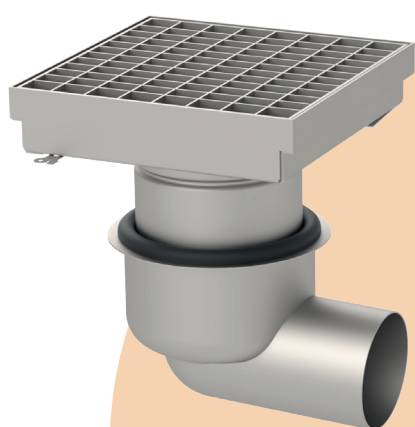

Siphons

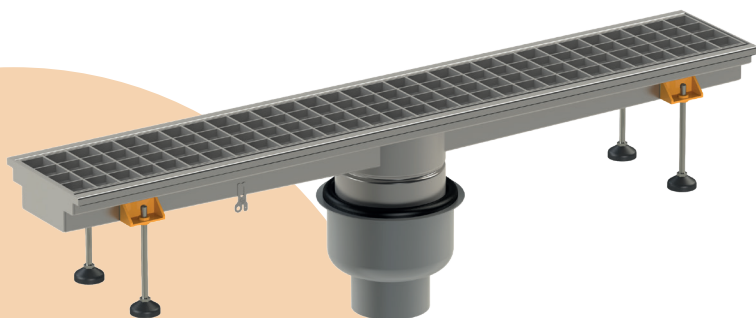

Manhole covers





TREATMENT

AN EXTENSIVE RANGE OF WATER PRE-TREATMENT AND TREATMENT PRODUCTS

- INDUSTRIAL SITES • COVERED CAR PARKS • PETROL STATIONS
- WASHING AREAS • ROADS • FOOD SERVICE • DRY DOCK AREAS

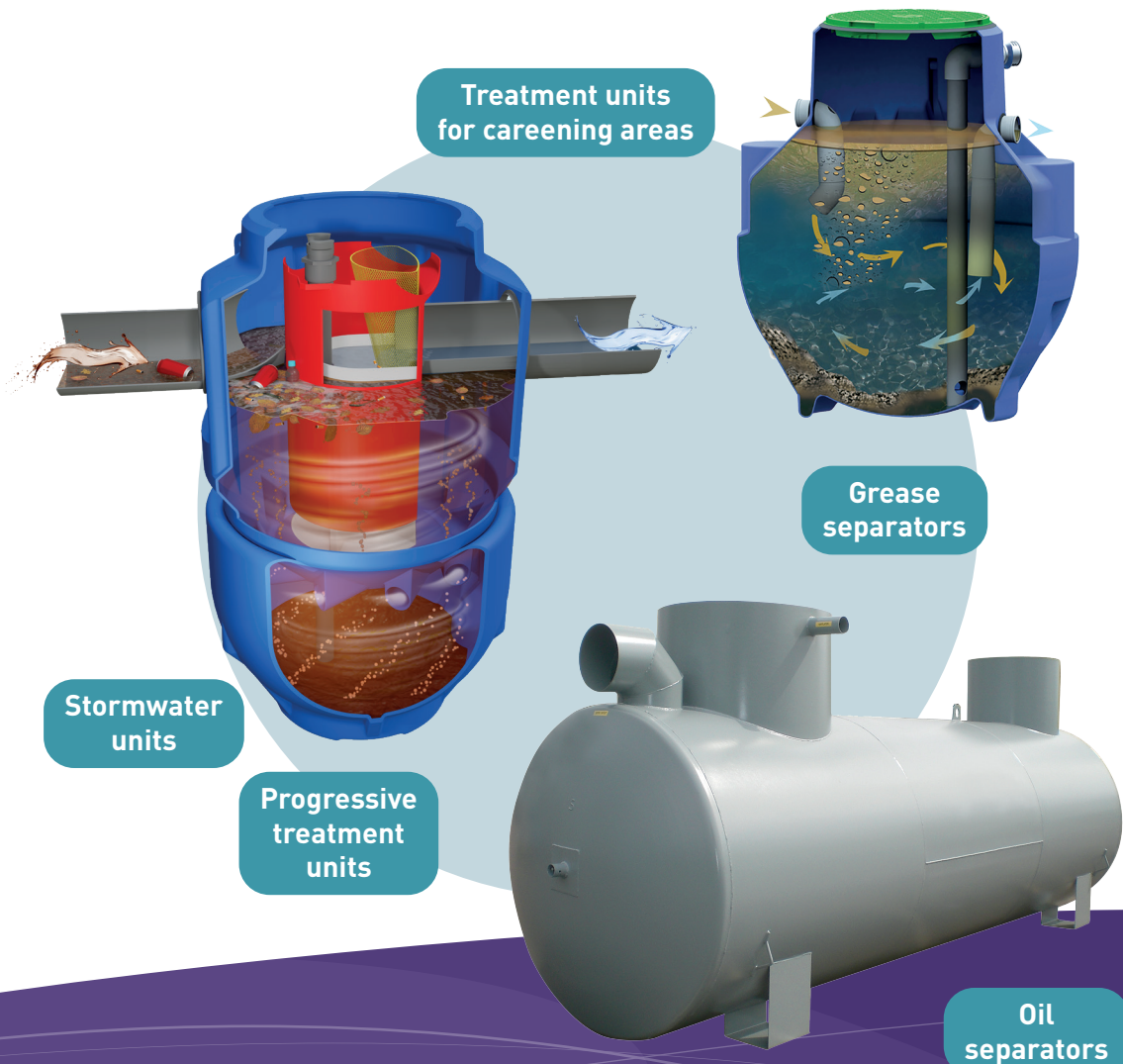



PUMPING

PUMPING STATIONS TAILORED TO ALL NEEDS

- **INDIVIDUAL HOUSE**
- **SMALL COMMUNITY**
- **COMMUNITY**



Small community
pumping stations

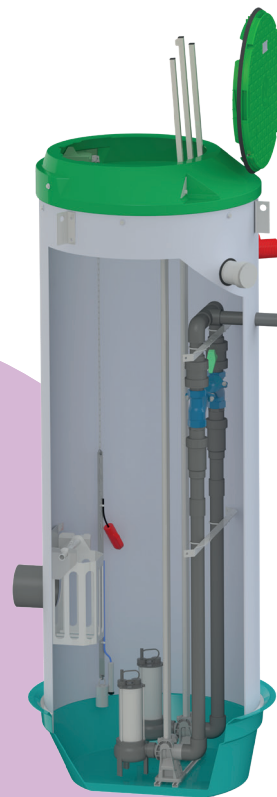

Individual
pumping
stations

Community
pumping
stations

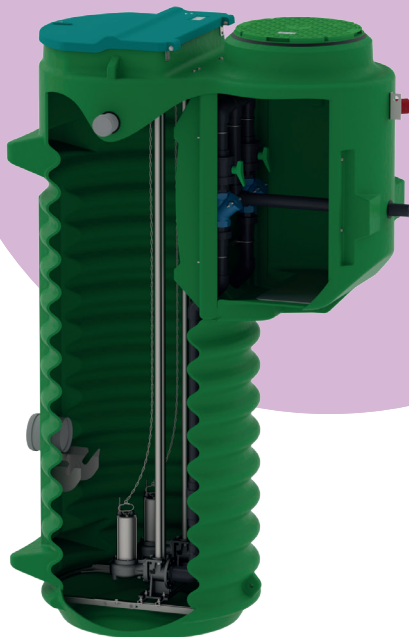



REGULATION

A RANGE OF EQUIPMENT TO REGULATE AND CONTROL WATER

- WASTE WATER
- STORMWATER

Penstocks



Large capacity regulation tanks

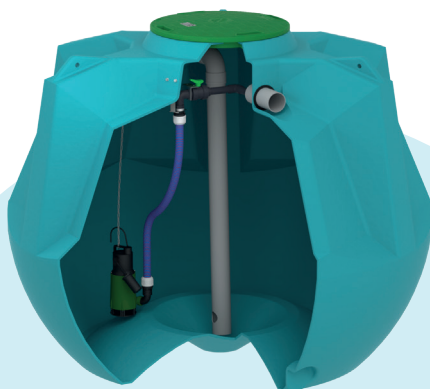

Parcel-based regulation tanks

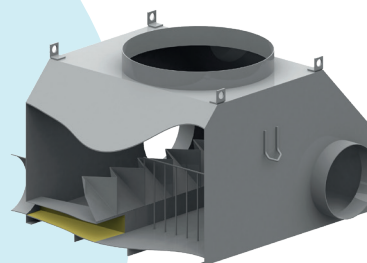

Flow controllers

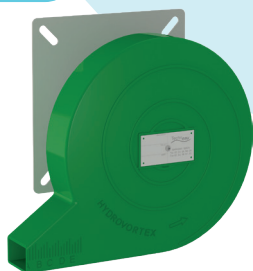

Control chambers

Flow regulators





STORAGE

TANKS DESIGNED FOR STORAGE

- DOMESTIC WATER • DRINKING WATER • PLANT PROTECTION EFFLUENTS
- ORGANIC • OILS • FARMING • WINE PRODUCTION

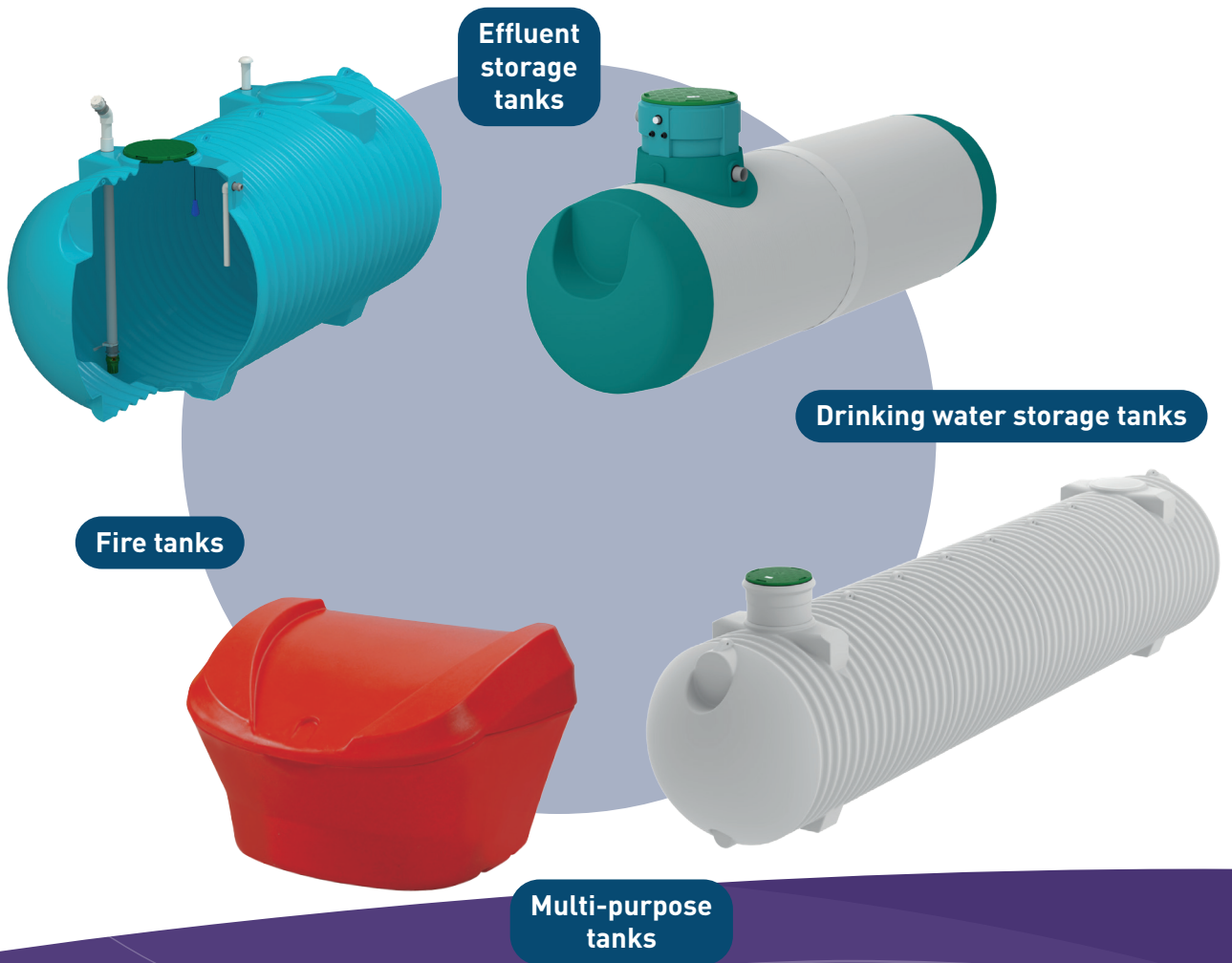



RECOVERY

FOR SMART REUSE OF STORMWATER

- HOMES • COMMUNITIES • SHOPPING CENTRES • SCHOOLS
- STADIUMS • GARDENS • INDUSTRIES • FARMING



- For designing the products of the future, **10 employees in the design and R&D office** are responsible for evaluating your needs and anticipating the products of the future.
- **24 representatives in the field** and 12 technical sales people at our headquarters are fully dedicated to assessing your needs and offering the most suitable technical solutions for your projects.
- **3 subsidiaries** specialising in metalworking and industrial plastic work have provided cutting-edge water management solutions over 30 years
- The group's products are sold in **Europe**, as well as exported **all over the world**.
- All tanks are made in **Normandy, France**.



KEY FIGURES

- **3** COMPLEMENTARY BUSINESSES
- **2** EUROPEAN SUBSIDIARIES
- **13 000 M²** OF PREMISES
- **180** EMPLOYEES
- **45 000** PRODUCTS SOLD PER YEAR
- **45 M€** IN ANNUAL SALES

AS A PART OF OUR ONGOING COMMITMENT TO **QUALITY** AND **PERFORMANCE**, OUR COMPANIES ARE CERTIFIED



Your specialist supplier

TECHNEAU, PLASTEAU and CHAUDREAU are subsidiaries of the GAEAU DÉVELOPPEMENT group



info@techneau.com
+33 (0)2 33 56 62 08
www.techneau.com



info@plasteau.com
+33 (0)2 33 77 18 40
www.plasteau.com



+33 (0)2 33 05 91 80
www.chaudreau.fr

