

The main title of the catalogue, "Water Lifting Catalogue", written in large, bold, white sans-serif font on a green background.

Water Lifting Catalogue

Text describing the types of pumping stations covered in the catalogue.

Polyethylene or polyester pumping stations for:

Text describing the first application category.

Private homes

Text describing the second application category.

Small residential blocks

Text describing the third application category.

Residential blocks



A *Techneau* centre of skilled experts at your service

Illustration of our involvement in yacht racing: the Class40 *Techneau* boat participating in the prestigious 2010 Route du Rhum yacht race

On a ten-hectare industrial site located in Marigny, *Techneau* has been able to bring together all the skills needed for creating, developing, manufacturing and marketing its products.

Techneau's journey started in 1991, where the company focused on creating and developing innovative techniques for water pre-treatment, treatment and lifting.

In 1998, *Techneau* was rapidly expanding and decided to create the company Plasteau to support it in its development of one-piece, rotomoulded, polyethylene hollow tanks.

Specialised in mass-produced products for storm water management and treatment for industrial businesses and local municipalities, the company now has in its workshops five machines that **rotomould hollow tanks up to 20 m³.**

Industrial boilermaking emerged in 2001 with Chaudreau.

Recognised industrial expertise

Techneau applies this expertise to standardise its production tool while remaining flexible enough to provide custom equipment and installations. Chaudreau continues its development, becoming a recognised player in the manufacturing of:

- moulds for the plastic and polyester industry
- hydraulic equipment (valves and flow regulators)
- water pre-treatment and treatment units
- ground-level equipment (manhole covers, siphons and stainless steel gutters)

The workshop's total surface area is 4,130 m², the total surface area of the offices and annexes is 310 m². The manufacturing facility includes:

- 1, 2 m x 4 m plasma cutting bench
- 3 folding presses, 2 shearing machines, 2 rolling machines
- 1 automated production line
- 1 painting tunnel,
- 1 second 80 m² painting site
- 1 automatic A5 welding gallow
- 1 digitally controlled nibbling-punching machine



Industrial boilermaking



The polyethylene rotomoulding unit



An integrated Research & Development department for designing the products of the future

The Research & Development department is made up of fifteen staff members responsible for **studying your needs and anticipating the products of the future.** The quality unit tests and validates each new product before it is marketed.

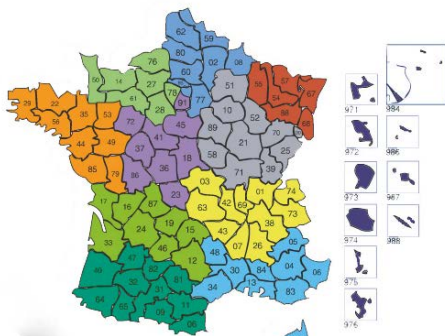

Sales department
FRANCE

Tel.: **+(33)2 33 56 62 08**

Sales department
OVERSEAS

Tel.: **+(33)2 33 56 66 43**

A sales department that caters to your needs

11 representatives in the field and 6 technical sales people at our headquarters are fully dedicated assessing your needs and offering the most suitable technical solutions for your projects.

With more than 26,000 technical offers per year, Techneau remains steadfast in its initial commitment: **guaranteeing you a precise, personalised assessment within 24 to 48 hours.**

A maintenance service at your service

3 technicians are available to assist you **anywhere in France** with commissioning your equipment.

A large stock of products and parts for effective responsiveness

70 references representing more than 350 items are continuously stocked so they can be shipped out the day you order them. With a lead time between 24 and 72 hours, an order made on Monday can be delivered to Perpignan on Thursday.

polyester station manufacturing



Assembly of Star 1000 pumping stations



24h

48h

72h

Place your order before midday for same-day shipping!



The Techneau water engineering department: providing a vast range of services



Industrial boilermaking



A maintenance department for the commissioning and servicing of your equipment.



An eight-hectare storage area



Production workshops



An on-site sales department for greater responsiveness

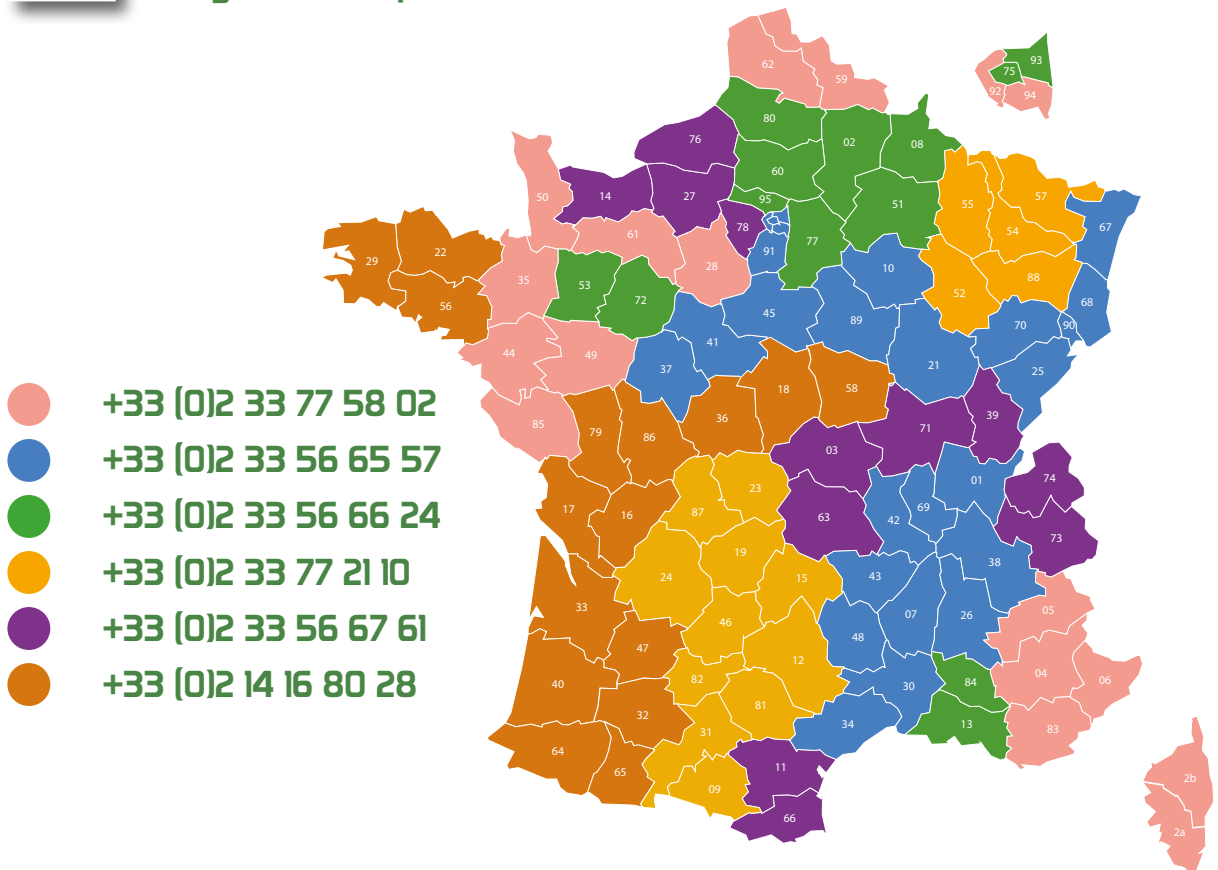



**A mobile sales force
for better in-person responsiveness**

- **BRITTANY**
+33 (0)6 08 43 76 43
- **BRITTANY/LOIRE**
+33 (0)6 85 30 85 22
- **NORMANDY**
+33 (0)6 07 09 84 36
- **CENTRAL WEST**
+33 (0)6 86 28 98 85
- **HAUTS DE FRANCE**
+33 (0)6 07 09 84 41
- **CENTRAL EAST**
+33 (0)6 82 04 99 07
- **EAST**
+33 (0)6 86 14 10 39
- **SOUTHWEST/AQUITAINE**
+33 (0)6 80 80 87 91
- **OCCITANIE/AQUITAINE**
+33 (0)6 89 64 02 40
- **AUVERGNE/RHÔNE ALPES**
+33 (0)6 85 66 23 82
- **SOUTHEAST**
+33 (0)6 75 22 99 39

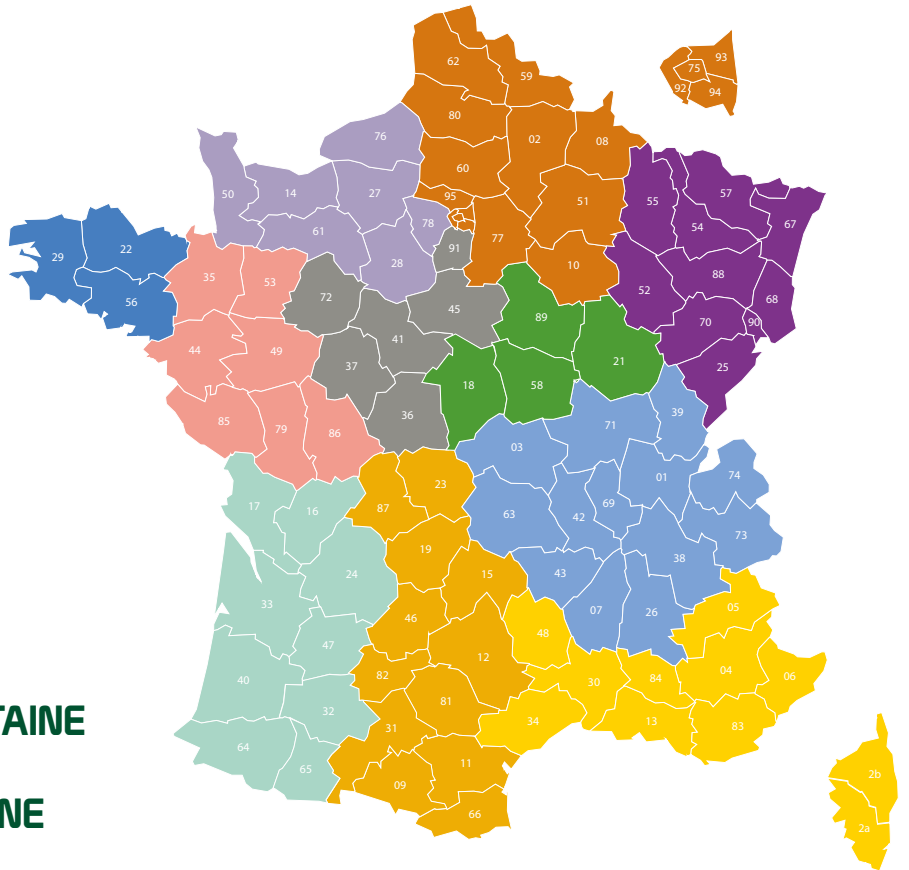

A NEARBY SALESFORCE
READY TO COME TO YOU





Operating principles of the pumping stations

The pumping station pump is activated and deactivated based on the height of the water in the tank.

1-Pump operating principle

Normal operating cycle: when the water rises in the tank and reaches **level 2**, the float switch activates the pump. When the level drops to **level 1**, the control box stops the pump. If **level 3** is reached, the (optional) alarm float activates a visual and sound signal that warns of an overflow risk.

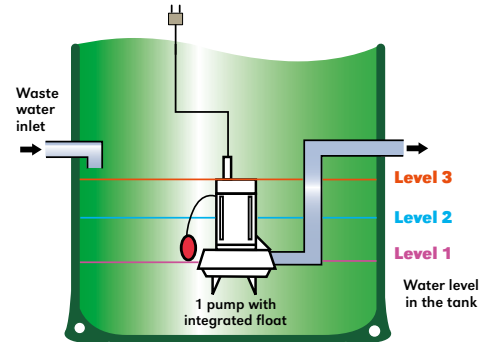

2-Pump operating principle



The **piezo probe** operates on pressure measurements. It is reliable and accurate. The interface on the front of the unit shows its operating status.

Normal operating cycle: when the water rises in the tank and reaches **level 2**, the pressure sensor activates one of the two pumps. When the level drops to **level 1**, the control box stops the pump. During the next cycle, it's the other pump that is activated: in this case, the operation of the pumps alternates.

Operating cycle in case of pump failure or flow rate overloading: in case of pump failure, the operational pump is automatically activated at **level 2**.

In a flow rate overloading situation: when the wastewater rises in the tank and reaches **level 2**, the pressure sensor activates one of the two pumps. When the level continues to rise and reaches **level 3**, the second pump is then activated. In this case, both pumps operate simultaneously.

Degraded operating mode:

If **level 4** is reached, the alarm float activates the two pumps as well as a visual and sound signal that warns of an overflow risk. The alarm float then deactivates two pumps.

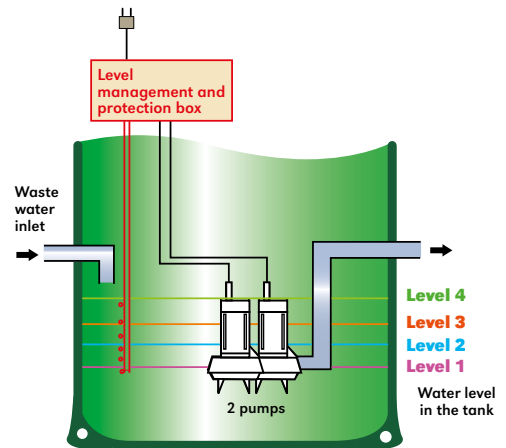

2 types of possible installations

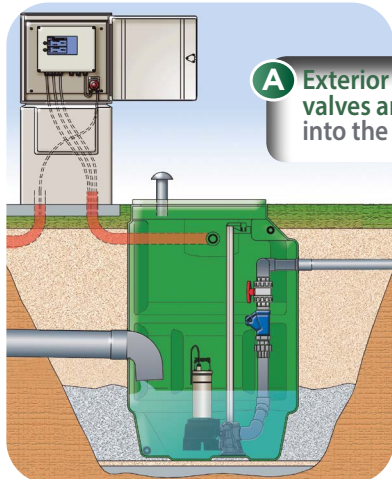

A Exterior installation with valves and gates integrated into the pumping station

Basic diagram of the STAR 900 with exterior electrical housing and ventilation

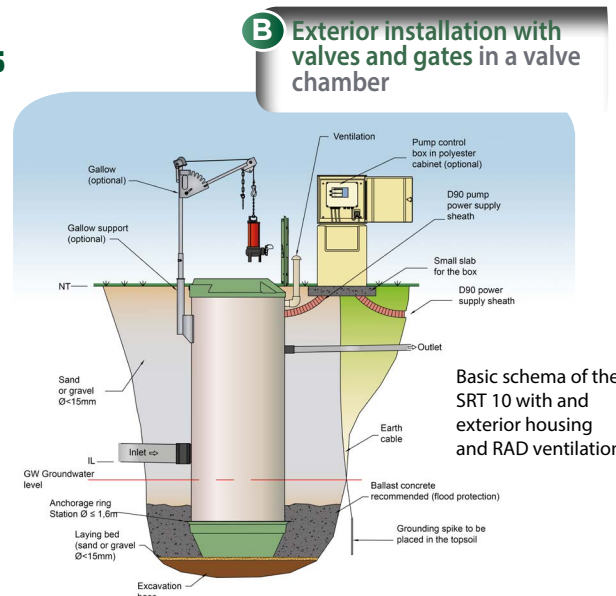

B Exterior installation with valves and gates in a valve chamber

Basic schema of the SRT 10 with exterior housing and RAD ventilation

Choose your unit for

contents

Private homes

private home



STAR 150 1 tripod pump	12
STAR 700 & 710 1 tripod pump	14
STAR 700 & 710 1 pump on a foot bracket	16

small residential block



STAR 900 1 Dn65 pump on a foot bracket.....	20
2 Dn50 pumps on foot brackets	22

Small residential block

residential block



STAR 1000 2 Dn50 pumps on foot brackets	26
Dn65	28
STAR 1200R integrated valve chamber 2 pumps on foot brackets	
Dn50	30
Dn65	32
SRT 10 2 pumps on foot brackets	
Dn50	34
Dn65	36
Dn50 with valve chamber	38
Dn65 with valve chamber	40

Residential block

Technical guide



Pumping station assessment: the form	44
Total Head (TDH): make your calculations	45

Control and protective electrical boxes	46
Installation guidelines STAR and SRT models	48
unit commissioning	54
Maintenance operations	55
Standards and CE marking	56
Equipment return form	57

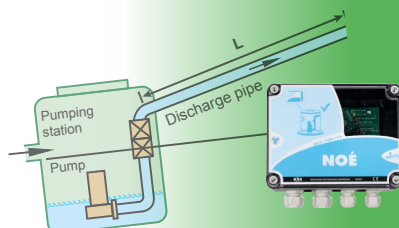

Technical guide





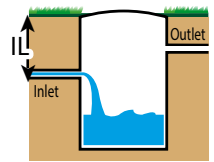



Choose for your inground pumping station: its inlet level for each type of installation

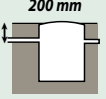

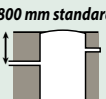
IL or the Inlet Level dimensions in the station are a determining factor when choosing your pumping station for inground installation outside the building.

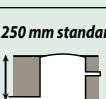
Private home

Depth of Inlet Level (IL)	Effluent type	Recommended pumping station		Our advice
		Model	Page	
 200 mm	Residual or washing water	STAR 150 	12	Water lifting for garage outlet
 800 mm standard	Treated or raw waste water	STAR 700 	14	
 1250 mm standard	Treated or raw waste water	STAR 710 	16	



Choices for a private home, according to the pumping and discharge height

A with a Dn32 (1" 1/4) or a Dn40 (1"1/2) PVC pipe:

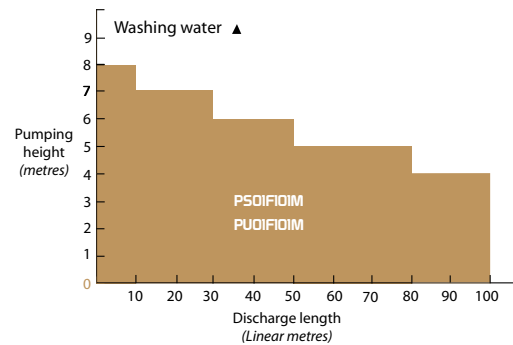
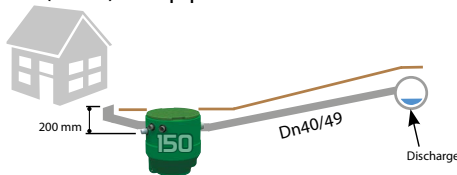

B with a Dn50 (2") PVC pipe:

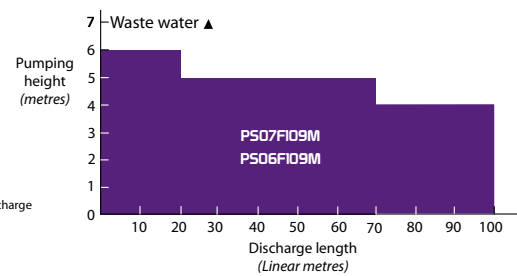
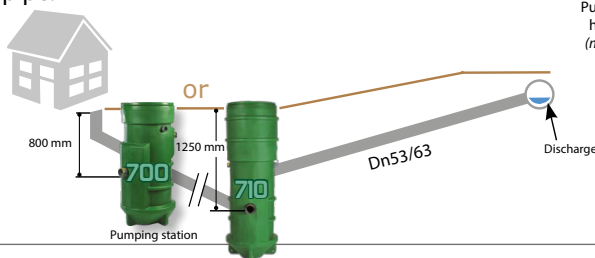

C with a Dn65 (12"1/2) PVC pipe:

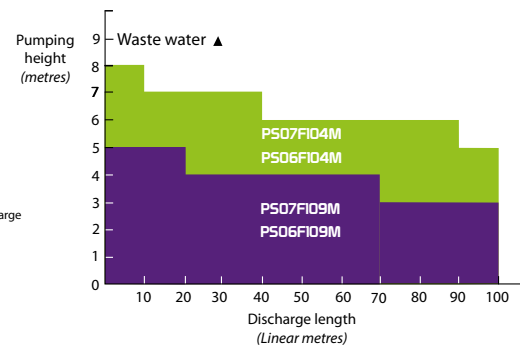
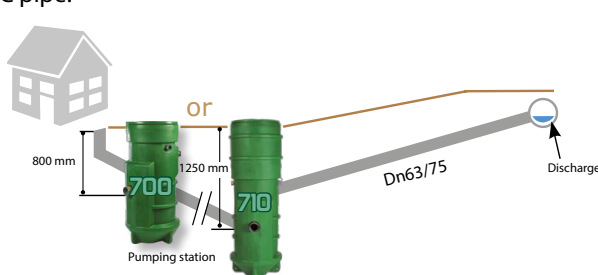



Choose for your in-ground pumping station: its inlet level for each type of installation

IL or the Inlet Level dimensions in the station are a determining factor when choosing your pumping station for in-ground installation outside the building.

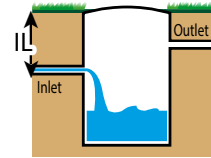

Small residential block Dimensions in mm

Depth of Inlet Level (IL)	Effluent type	Recommended pumping station		Our advice
		Model	Page	
900 mm standard 	Raw waste water and sewage	STAR 900	20	Pumping station specifically adapted to public areas
400 or 900 mm 	Treated or raw waste water	STAR 900	22	Large choice of pumps for 2 possible ILs

Residential block Dimensions in mm

Depth of Inlet Level (IL)	Effluent type	Recommended pumping station		Our advice
		Model	Page	
1200 or 1700 mm 	Treated or raw waste water	STAR 1000	26	Perfectly adapted for housing estates 2 ILs available, PUE model With integrated valve chamber, PURE model
			28	
> 1730 mm up to 3820 mm 	Treated or raw waste water	STAR 1200R	30	
			32	
> 1700 mm up to 5200 mm 	Treated or raw waste water	SRT 10	34	Ideal for deep inlet levels, PUP model
			36	
> 1700 mm up to 5200 mm 	Treated or raw waste water	SRT 10	38	With exterior valve chamber, PURP model
			40	





Pumping stations
for **private**
homes

Star 150 1 tripod pump _____ p.12-13

Star 700 and 710 1 tripod pump _____ p.14-15

Star 700 and 710 1 pumps on foot brackets _____ p.16-17



STAR150 1 tripod pump

regulated
by
float
switches



Displayed model
PS07F101M

Product advantages
Unit designed for shallow installations

Use

- Adapted for waste water lifting or for water with low particle content (post-treatment) from a private home.
- Designed for inground installation outside the building.

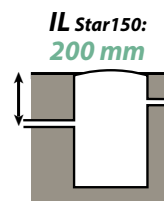

Design

- Polyethylene corrosion-proof tank.
- Tilted bottom for better sludge discharge and reduced H₂S formation.
- 2 anchorage rings.
- Usable sub-inlet volume: 125 L.
- Quarter-turn cover closure with 1-nut lock for improved safety.
- Female PVC bonding entry sleeve for exterior Ø 100 PVC pipe.
- Exterior Ø 40 pressure outlet pipe.
- Female PVC ventilation sleeve for exterior Ø 50 PVC pipe.
- Female PVC cable gland sleeve with stopper exterior Ø 50 PVC pipe.

Interior equipment

- 1 230 V single-phase submerged pump: Feka 600 model (see opposite),
- PN16 PVC pressure discharge pipe,
- Dn32 PVC non-return ball valve.

Non-contractual texts, dimensions, photos and diagrams

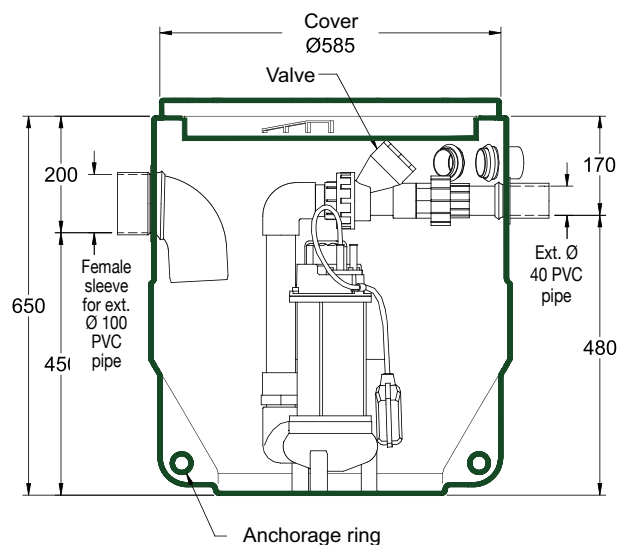
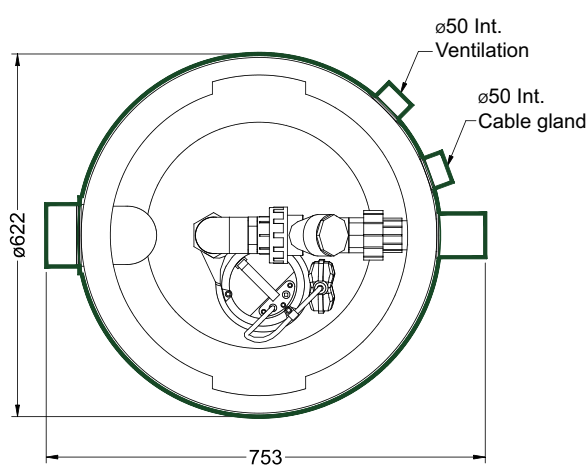

STAR₁₅₀



The pump



**RESIDUAL
OR WASHING
WATER**

230 V single-phase

Construction: pump housing, polymer engine cover and Vortex wheel.

Integrated float.

Protection: IP68, insulation class F.

Use: *low particle content liquids.*

Flow area: 25 mm.

Discharge: 1"1/4.

Connection only with 230 V outlet + earthing.

Equipped with a 5-metre cable.

Weight 7.2 kg.

Model selection

Based on flow rate and Total Head (TDH). If you do not know which one to select, refer to page 9 to select the model or to page 45 to calculate the flow rate and TDH.

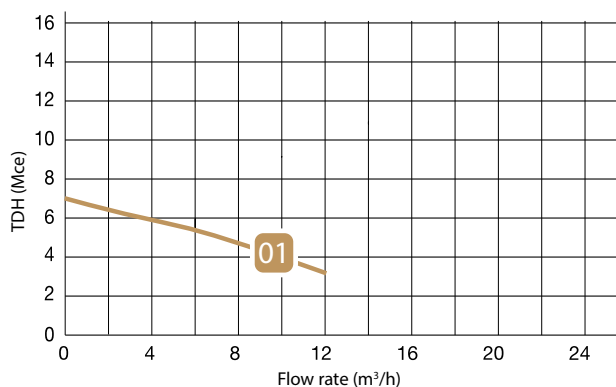

01 FEKA 600 M Auto

Options



Polyethylene extensions

Fixed height 200 mm.
Fixed height 400 mm.

PLA13555
PLA13556



Never stack 2 extensions on top of each other. The unit should be installed as shallow as possible to make its servicing easier and avoid ground overload on the tank,



Float switch

with 10 LM cable.

RB10

Sealed connection kit

IP68 for 24 hrs. under 2 m of water. For pulling out the pumps or level regulators from the pumping station without pulling out the sheath cables.

• Single-phase and triple-phase pumps from this catalogue **14871**

• Level regulators..... **14532**



Caution: a cabled connection kit needs to be installed



CP03

Alarm and control box

Install the RB10 float switch For 5A pump max.



See detailed description page 47

Non-contractual texts, dimensions, photos and diagrams

Technical data and features

Reference	Curve/pump No.	Pump type	Flow area (mm)	Ø Inlet (mm)	Ø Outlet (mm)	Amperage (amps)	Voltage (volts)	Power (kW)	Unit weight (kg)
PS01F101M	01	FEKA 600 M Auto	25	for ext. Ø 100 PVC pipe	ext. Ø 40 PVC pipe	4.3	230 V Single	0.55	18



STAR700 and 710

1 tripod pump

regulated
by
float
switches



STAR 700 model
PS07F101M

STAR 710 model
PS06F101M

Use

- Adapted for waste water lifting or for water with low particle content (post-treatment) from a private home.
- Designed for inground installation outside the building.

Design

- Polyethylene corrosion-proof tank.
- Tilted bottom for better sludge discharge and reduced H₂S formation.
- 3 anchorage rings,
- Usable sub-inlet volume: 150 L,
- Quarter-turn cover closure with 1-nut lock for improved safety,
- Female PVC bonding entry sleeve for exterior Ø 100 PVC pipe.
- Exterior Ø 40 or Ø 63 PVC pressure outlet pipe,
- Female PVC ventilation sleeve for exterior Ø 50 PVC pipe,
- Female PVC cable gland sleeve with stopper exterior Ø 50 PVC pipe.

IL Star 700:
Standard 800 mm

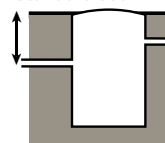

Upon request
from 600 to 900 mm

Standard 1250 mm

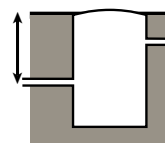

Upon request
from 1050 to 1350 mm

Interior equipment

- 1 submerged pump,
- PN16 PVC pressure discharge pipe,
- Dn32 PVC non-return ball valve and Dn32 PVC ball valve attached on a union for pump no. 1,
- Dn40 PVC non-return ball valve and Dn40 PVC ball valve attached on a union for pump no.



STAR 710 model displayed with
detail of the ball valve

Product
advantages

Unit designed for deep
installations

Non-contractual texts, dimensions, photos and diagrams

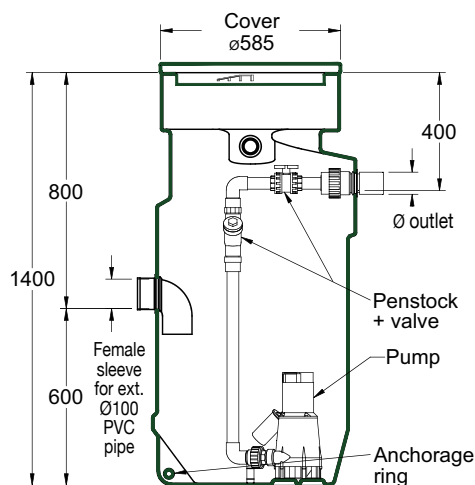
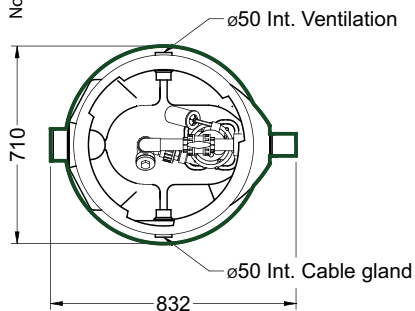

STAR 700 model

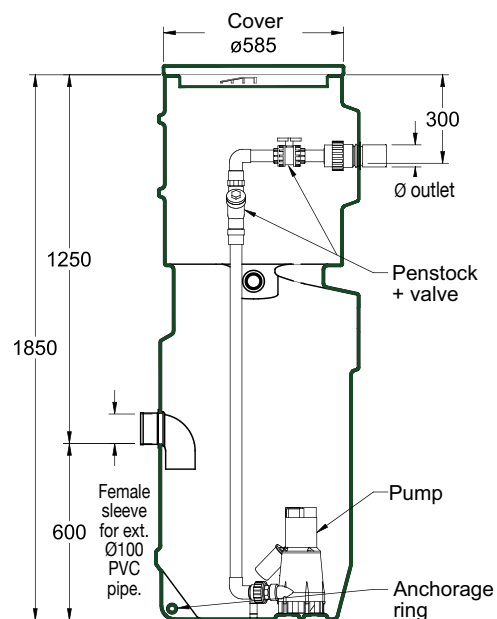

STAR 710 model

STAR700 and 710

Model selection based on flow rate and Total Head (TDH).

If you do not know which one to select, refer to page 9 to select the model or to page 45 to calculate the flow rate and TDH.

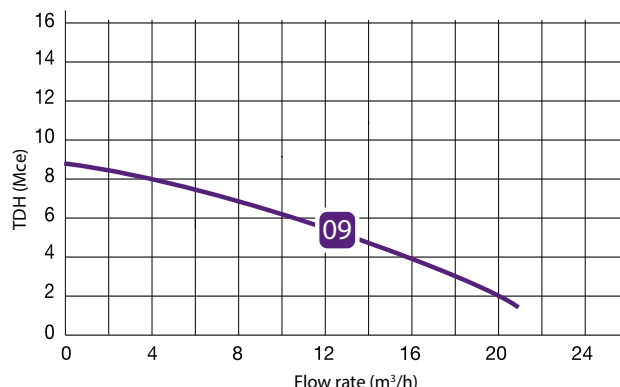
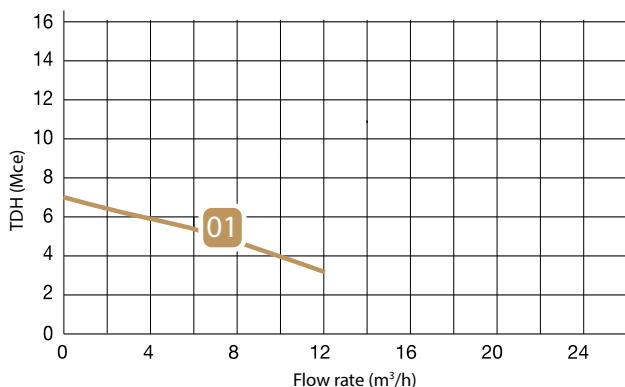

The pump

230 V single-phase

Integrated float.

Construction:

- FEKA 600M Auto: Pump housing, Vortex wheel and polymer engine cover,
- SEMISOM 290M Auto: Pump housing, cast-iron Vortex wheel, stainless steel engine cover,

Protection: IP68, insulation class F,

Temperature of liquids:

- Feka 600: +35°C max.;
- Semisom 290M: +50°C max.



01 FEKA 600M Auto

WATER WITH LOW PARTICLE CONTENT AFTER SEPTIC TANK

Flow area: 25 mm.
 Discharge: 1"1/4.
 Power: 0.55 Kw.
 Amperage: 4.3 A.
 Connection only with 230 V outlet + earthing.
 Equipped with a 5-metre cable.
 Weight: 7.2 kg.



09 SEMISOM 290M Auto

PARTICLE-LADEN WATER

Use: *particle-laden water.*
 Flow area: 50 mm.
 Discharge: 2".
 Power: 0.55 Kw.
 Amperage: 4.2 A. Equipped with a 10-metre cable.
 Weight: 14.5 kg.

Non-contractual texts, dimensions, photos and diagrams

Options



Drilling kit

KITP100

Complete kit with 1 hole saw, 1 seal and 1 stopper. Dn100. For plugging the standard inlet and drilling another Dn100 inlet of your own choosing.



Polyethylene extensions

- Fixed height 200 mm **PLA13555**
- Fixed height 400 mm **PLA13556**

Never stack 2 extensions on top of each other. The unit should be installed as shallow as possible to make its servicing easier and avoid ground overload on the tank,



Alarm and control box

CP03

Use with the RB10 float ball For 5A pump max.

➔ See detailed description page 47



Sealed connection kit

IP68 during 24 hrs. under 2 m of water. For pulling out the pumps or level regulators from the pumping station with pulling out the sheath cables.

- Single-phase and triple-phase pumps from this catalogue **14871**

- Level regulators..... **14532**



Caution: a cabled connection kit needs to be installed

Technical data and features

STAR 700 Ht. 1400 mm	Station weight (kg)	STAR 710 Ht. 1800 mm	Station weight (kg)	Bend/pump No.	Pump type	Flow area (mm)	Ø Inlet (mm)	Ø Outlet (mm)	Amperage (amps)	Voltage (volts)	Power (kW)
PS07F101M	43	PS06F101M	50	01	FEKA 600 M Auto	25	for ext. Ø100 PVC pipe	ext. Ø40 PVC pipe	4.3	230 V Single	0.55
PS07F109M	50	PS06F109M	57	09	SEMISOM 290 M Auto	50		ext. Ø63 PVC pipe	4.2		



STAR700 and 710 1 pump on a foot bracket

regulated
by
float
switches



STAR 700 model
PU07F104M

STAR 710 model
PU06F104M

Use

- Adapted for waste water lifting or for water with low particle content (post-treatment) from a private home.
- Designed for inground installation outside the building.

Design

- Polyethylene corrosion-proof tank,
- Tilted bottom for better sludge discharge and reduced H₂S,
- 3 anchorage rings,
- Usable sub-inlet volume: 150 L,
- Quarter-turn turn cover closure with 1-nut locking for improved safety,
- Female PVC bonding entry sleeve for exterior Ø 100 PVC pipe.
- Exterior Ø 40 or 63 PVC pressure outlet pipe,
- Female PVC ventilation sleeve for exterior Ø 50 PVC pipe,
- Female PVC cable gland sleeve with stopper exterior Ø 50 PVC pipe.

IL Star 700:

Standard 800 mm



Upon request
from 600 to 900 mm

IL Star 710:

Standard 1250 mm

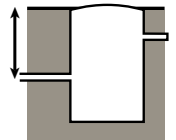

Upon request
from 1050 to 1350 mm

Interior equipment

- 1 submerged pump,
- Foot bracket system with composite guiding bars for easier pump installation (Feka 600M auto: stainless steel guiding bars),
- PN16 PVC pressure discharge pipe,
- Dn32 PVC non-return ball valve and Dn32 PVC ball valve attached on unions for pump no. 1,
- Dn50 cast-iron non-return ball valve and Dn50 PVC ball valve attached on unions for pumps no 9 and 4.

Product advantages

Pumps installed on foot brackets can be easily disassembled without disrupting the tank.



Detail of pup interior
(Semisom 290M Auto
on a composite foot
bracket)

Non-contractual texts, dimensions, photos and diagrams

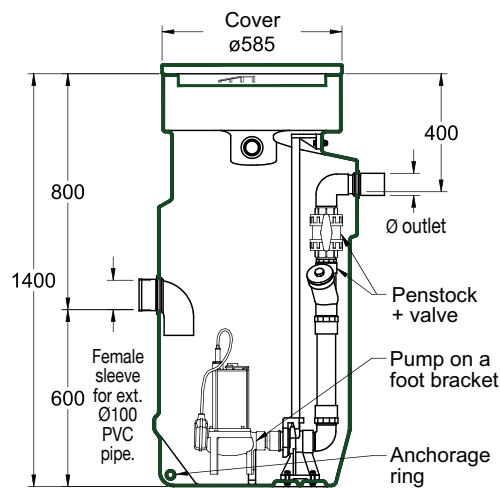
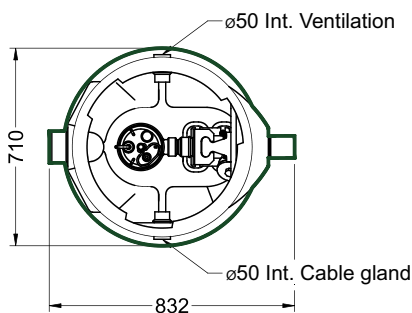

STAR 700 model

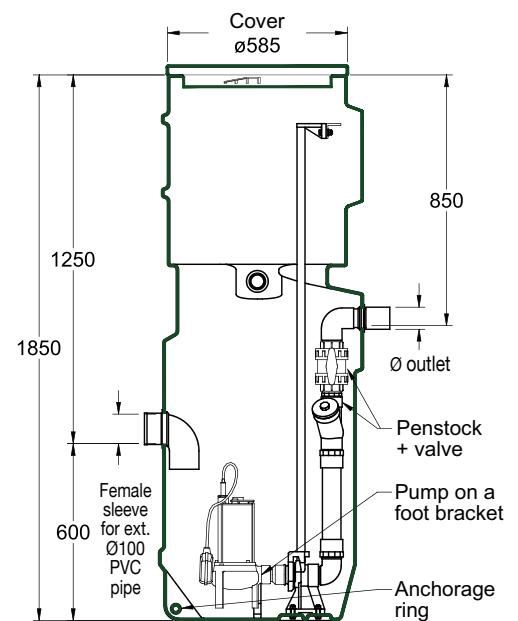

STAR 710 model

STAR700 and 710



Model selection based on flow rate and Total Head (TDH).

If you do not know which one to select, refer to page 9 to select the model or to page 45 to calculate the flow rate and TDH.

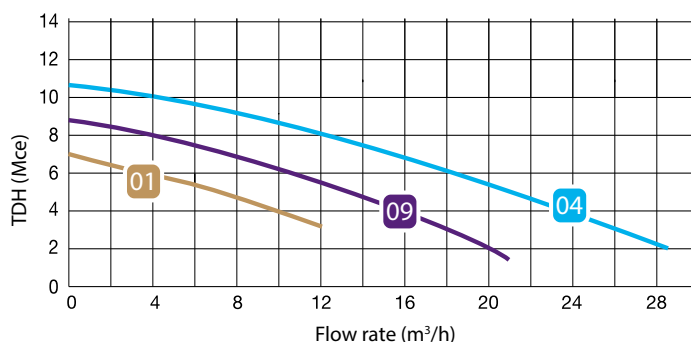

The pump

230 V single-phase.

Integrated float.

Construction: pump housing, cast-iron Vortex wheel and stainless steel engine cover (except FEKA 600M Auto: unit made out of polymer),

Protection: IP68, insulation class F,

Temperature of liquids: Feka 600: +35°C max.; Semisom 290 and 490 M Auto: +50°C max.

WATER WITH LOW PARTICLE CONTENT AFTER SEPTIC TANK



Flow area: 25 mm.
Discharge: 1"1/4.
Power: 0.55 Kw.
Amperage: 4.3 A.
Connection only with 230 V outlet + earthing.
Equipped with a 5-metre cable.
Weight: 7.2 kg.

01 FEKA 600M Auto

PARTICLE-LADEN WATER



Flow area: 50 mm.
Discharge: 2".
Power: 0.55 Kw.
Amperage: 4.2 A.
Equipped with a 10-metre cable.
Weight: 14.5 kg.

09 SEMISOM 290M Auto

PARTICLE-LADEN WATER



Flow area: 50 mm.
Discharge: 2".
Power: 1.1 Kw.
Amperage: 7.3 A.
Equipped with a 10-metre cable.
Weight: 20 kg.

04 SEMISOM 490M Auto

Options



Alarm and control box

Install the RB10 float switch For 5A pump max. (not adapted for Semisom 490M Auto).

CP03

CP04

See detailed description page 47



Float switch

with 10 LM cable.

RB10



Drilling kit

KITP100

Complete kit with 1 hole saw, 1 seal and 1 stopper. Dn100. For plugging the standard inlet and drilling another Dn100 inlet of your own choosing.



Polyethylene extensions

Fixed height 200 mm.

Fixed height 400 mm.

PLA13555

PLA13556

Never stack 2 extensions on top of each other.

The unit should be installed as shallow as possible to make its servicing easier and avoid ground overload on the tank.



Sealed connection kit

IP68 for 24 hrs. under 2 metres of water. For pulling out the pumps or level regulators from the pumping station with pulling out the sheath cables.

- Single-phase and triple-phase pumps from this catalogue ..

14871

- Level regulators

14532

Caution: a cabled connection kit needs to be installed.



Technical data and features

STAR 700 Ht. 1400 mm	Station weight (kg)	STAR 710 Ht. 1800 mm	Station weight (kg)	Curve/ pump No.	Pump type	Flow area (mm)	ø Inlet (mm)	Ø Out- let (mm)	Amperage (amps)	Voltage (volts)	Power (kW)
PU07F101M	40	PU06F101M	47	01	FEKA 600 M Auto	25	for ext. ø 100 PVC pipe	Ext. ø 40 PVC pipe	4.3	230 V Single	0.55
PU07F109M	46	PU06F109M	53	09	SEMISOM 290 M Auto	50		Ext. ø 63 PVC pipe	4.2		
PU07F104M	67	PU06F104M	74	04	SEMISOM 490 M Auto	50			7.3		

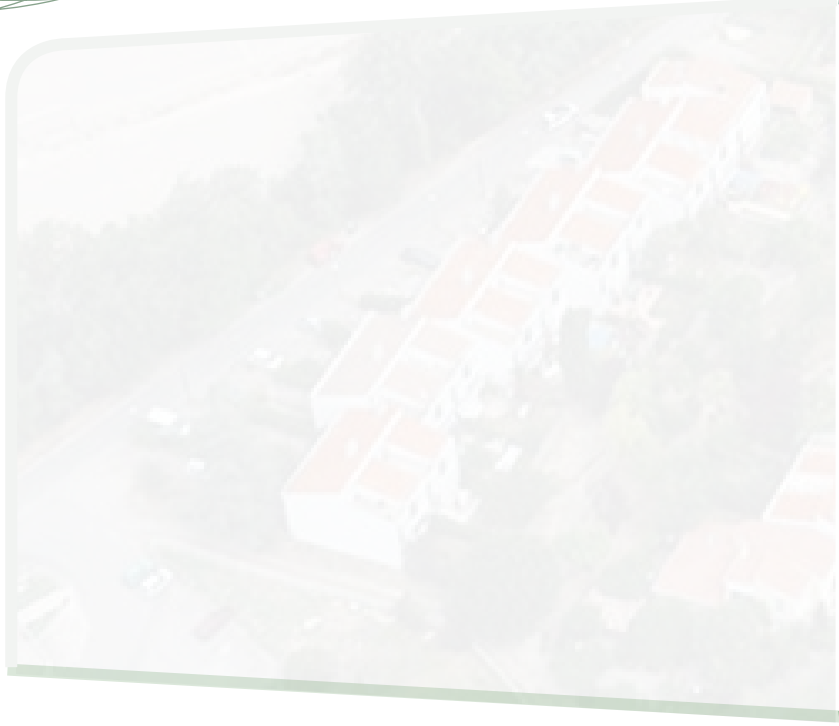



Pumping station
for **small residential
blocks**

Star 900 1 Dn65 pump on foot brackets — p.20-21

Star 900 2 Dn50 pumps on foot brackets — p.22-23



STAR 900 1 Dn65 pump on a foot bracket



Product advantages

Model specifically adapted for public areas.
Non-clogging pump



Height 1.50 m
ref. PU15F103M

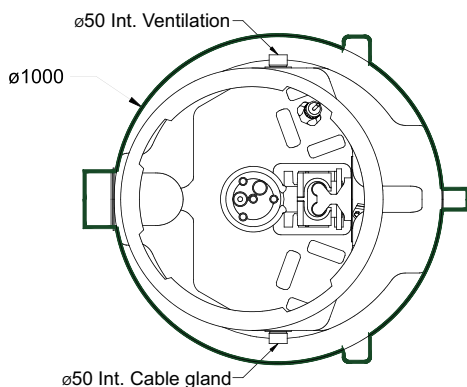

ø50 Int. Ventilation

ø1000

ø50 Int. Cable gland

Use

- Adapted for particle-laden water lifting in small residential blocks
- Designed for inground installation outside the building.

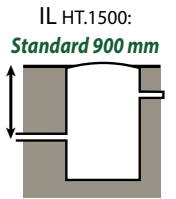

Upon request from 400 to 900 mm

Design

- Polyethylene corrosion-proof tank with anchorage ring,
- Usable sub-inlet volume: 350 L,
- 1/4 turn cover closure with 1-bolt locking for improved safety,
- Female PVC bonding entry sleeve for exterior Ø 160 PVC pipe,
- Exterior Ø 75 PVC pressure outlet pipe,
- Female PVC ventilation sleeve for exterior Ø 50 PVC pipe,
- Female PVC cable gland sleeve with stopper exterior Ø 50 PVC pipe.

Equipment

- 1 submerged pump with its starter box
- Cast-iron foot bracket system with stainless steel guiding bars (easier pump installation),
- PN16 PVC pressure discharge pipe,
- Dn65 PVC non-return ball valve and Dn65 PVC ball valve attached on unions,
- 1 alarm float.

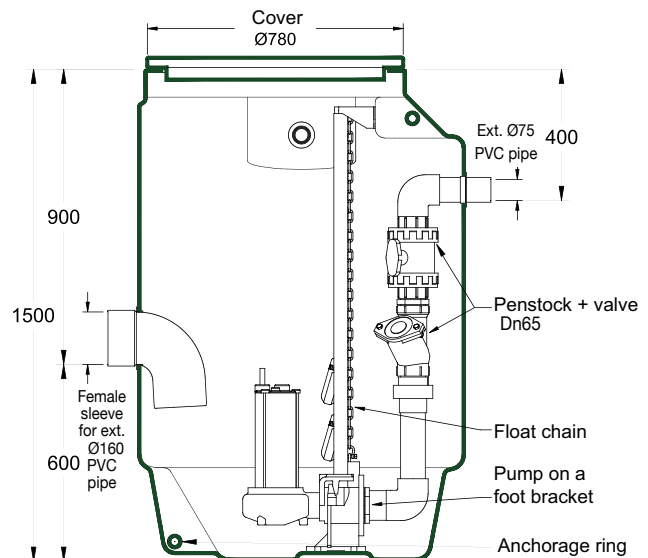

Total weight: 150 kg.

STAR900



The pump

SPECIFICALLY ADAPTED
TO PUBLIC AREAS
NON-CLOGGING



**230 V single-phase
or 400 V triple-phase**

Model with large flow area.

Construction: pump housing and cast-iron Vortex wheel. Stainless steel engine cover and tie rods

Protection: IP68, insulation class F.

Temperature of liquids: +50°C max.

Use: liquid with large particle content.

Flow area: 65 mm.

Discharge 2" 1/2.

Power 1.5 Kw.

Amperage: 12 A (230 V single-phase) or 4.6 A (400 V triple-phase)

Equipped with a 10-metre cable and 2 wires for isotherm

Weight 21 kg.

03 SEMISOM 650M or T

11 SEMISOM 650H M or T

Model selection based on flow rate and Total Head (TDH). If you do not know which one to select, refer to page 45 to calculate the flow rate and TDH.

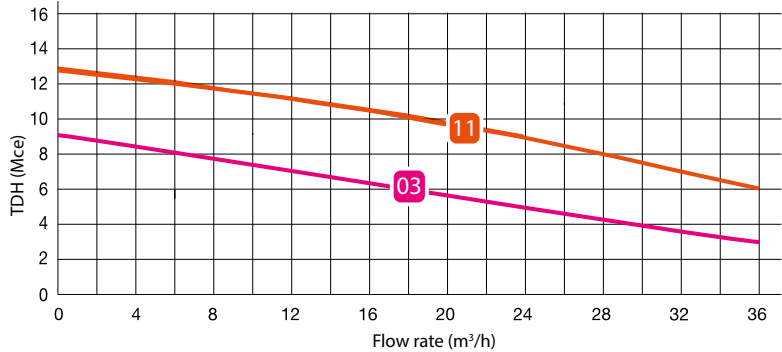

Delivered with



400 V triple-phase pump
Protection and starter box with alarm.

CP01RS

Use

- **Protection and control box:** Protect the pump motor from overcurrents and blockages.

Technical features

- 400-volt triple-phase.
- IP55 watertightness.
- Plug-in electronic card.
- On/Off switch, sound alarm, power indicator light, mains indicator light, trip indicator light.
- Alarm transfer terminal block.
- Terminal block for connecting alarm regulator.
- Power coupling with a protective/two-pole or three-pole sectioning device, EN 60204 standard.
- **Volume: 250 L x 120 D x 180 H mm.**
- Force start.

OR



230 V single-phase pump
Protective and starter box with capacitors and alarm.

CD650-EVOL

Use

- **Sealed protection and control box:** it protects the pump motor from overcurrents, overheating and blockages.

Technical features

- 230 volt single-phase.
- IP55 watertightness.
- On/Off switch, power indicator light, mains indicator light, fault indicator light.
- Terminal block for connecting alarm regulator, with relays in case of main float failure.
- Power coupling with two-pole or three-pole protection device, EN 60204 standard.
- **Volume: 230 L x 130 D x 300 H mm.**

Single-phase references	Curve/pump no.	Pump type
PU15F103M	03	SEMISOM 650 M
PU15F111M	11	SEMISOM 650H M

Three-phase references	Curve/pump no.	Pump type
PU15F103T	03	SEMISOM 650 M
PU15F111T	11	SEMISOM 650H T



Important

Our boxes are coupled to a power supply equipped with a protective, two-pole or three-pole sectioning device depending on the circumstances, in compliance with the EN 60204 standard.

Non-contractual texts, dimensions, photos and diagrams

SMALL RESIDENTIAL BLOCK

Options

Cover extensions

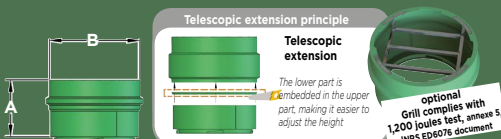

After the second stacked extension, a concrete slab is necessary. The unit should be installed as shallow as possible to make its servicing easier and avoid ground overload on the tank.

References	A (mm)	B (mm)	Weight (kg)	Telescopic	Fall protection grill
ETR47EF	490	780	10.5 kg	•	•
ETR65EF	650	780	18 kg	•	•

Cabinet with base for exterior installation

In polyester 540 L x 520 H x 240 D m + 580 mm base height for installing a 1- or 2-pump electrical box

CP510

Anchoring kit

3 steel components
Composed of a tank attaching bracket and a welded steel mesh, the kit facilitates anchoring the tank in case of groundwater
Weight: 8.5 kg.

OSE73050



STAR900 2 Dn50 pumps on foot brackets



Commissioning:
contact us

Displayed model:
ref. PU15P216M

Use

- Adapted for water lifting in small residential blocks
- Designed for inground installation outside the building.

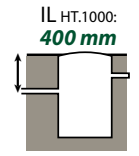

Design

- Polyethylene corrosion-proof tank with anchorage ring,
- Usable sub-inlet volume: 350 L,
- Quarter-turn cover closure with 1-nut locking for improved safety,
- Female PVC bonding entry sleeve for exterior Ø 160 PVC pipe.
- Exterior Ø 63 PVC pressure outlet pipe,
- Female PVC ventilation sleeve for exterior Ø 50 PVC pipe,
- Ø 76/90 TPC cable gland sheath.

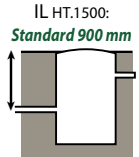

Upon request
from 400 to 900 mm

Interior equipment

- 2 submerged pumps,
- Cast-iron foot bracket system with composite guiding bars for easier pump installation,
- PN16 PVC pressure discharge pipes,
- 2 PVC non-return ball valves and 2 Dn50 PVC ball valves attached on unions,
- 1 alarm float (10-metre cable),
- 1 stainless steel piezo probe attached to a chain with counterweight (10-metre cable),
- SRI protection and control box.



- Protective, solid-waste basket.



Product advantages
Compact pumping station available in 2 different heights, depending on your installation site

Non-contractual texts, dimensions, photos and diagrams

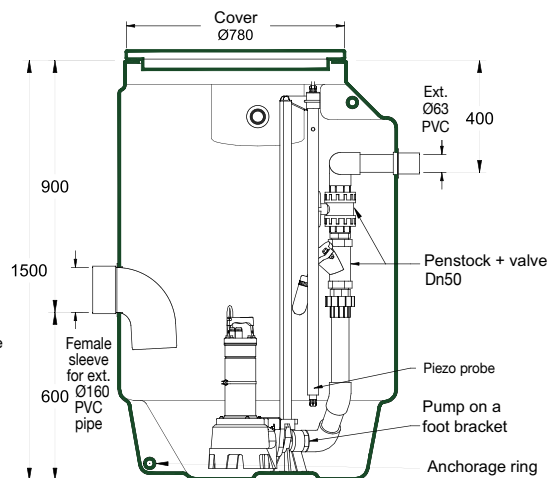
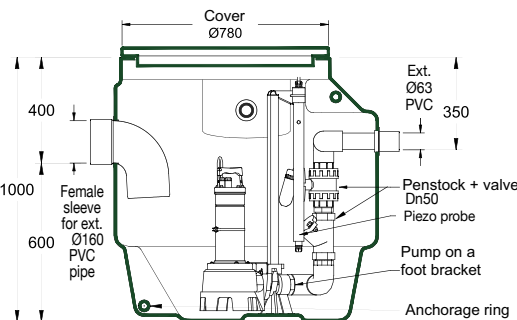
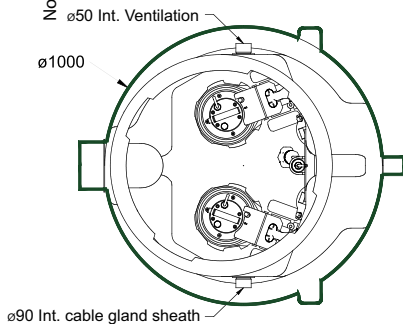

STAR900



The box and the probe

Technical features

- **230 Volt single-phase or 400 volt four-phase + neutral mode.**
- Automatic pump starts depending on the tank level.
- Automatic reverse at each start.
- Sound and visual alarm on alarm float.
- Lockable disconnecter.
- Push-button Force Start function on pumps.
- On/Off indicator display per pump.
- Dry contact for alarm transfer.
- **Volume:**
278 L x 130 D x 378 H mm

Piezo probe (10-metre cable)



For more info, see page 46

Model selection based on flow rate and Total Head (TDH). If you do not know which one to select, refer to page 45 to calculate the flow rate and TDH.

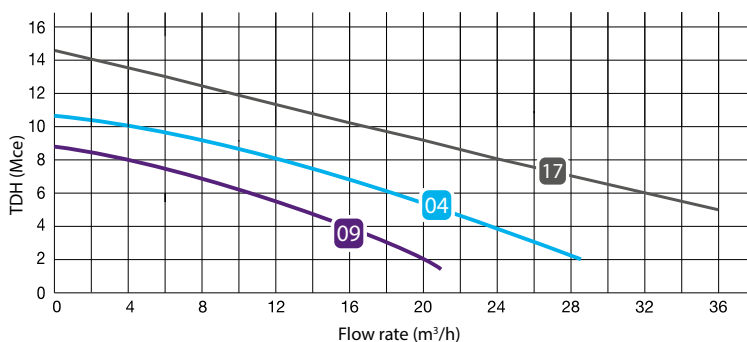

The pumps

230 V single-phase with capacitor integrated into the pump for models 290M and 490M. Capacitors integrated into the box for the model 590M.

Or 400 V three-phase pumps

Construction:

pump housing and cast-iron Vortex wheel, steel engine cover,

Protection: IP68, insulation class F,

Use: particle-laden water,

Flow area: 50 mm,

Temperature of liquids: +50°C max.

Equipped with a 10-metre cable.



Discharge: 2",
Weight: 14.5 kg.

09 SEMISOM 290M or T



Discharge: 2",
Weight: 20 kg.

04 SEMISOM 490M or T



Discharge: 2",
Weight: 18.2 kg.
2 wires for isotherm.

17 SEMISOM 590M or T

STAR 900 Ht. 1000 mm	Unit weight (kg)	STAR 900 Ht. 1500 mm	Station weight (kg)	Curve/pump No.	Pump type	Intensity (amps)	Voltage (volts)	Power (kW)
PU10P209M	100	PU15P209M	124	09	SEMISOM 290 M	4.2	230 V Single	0.55
PU10P209T		PU15P209T			SEMISOM 290 T	1.7	400 V Triple	
PU10P204M	105	PU15P204M	129	04	SEMISOM 490 M	7.3	230 V Single	1.1
PU10P204T		PU15P204T			SEMISOM 490 T	2.7	400 V Triple	
PU10P217M	107	PU15P217M	131	17	SEMISOM 590 M	10.5	230 V Single	1.5
PU10P217T		PU15P217T			SEMISOM 590 T	4.1	400 V Triple	

Options

Cover extensions

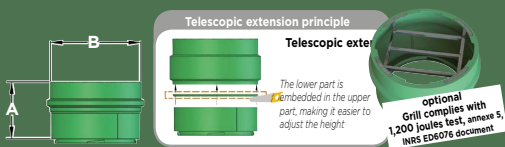

After the second stacked extension, a concrete slab is necessary. The unit should be installed as shallow as possible to make its servicing easier and avoid ground overload on the tank.

References	A (mm)	B (mm)	Weight (kg)	Telescopic	Fall protection grill
ETR47EF	490	780	10.5 kg	•	GI0670I
ETR65EF	650	780	18 kg	•	



Cabinet with base for exterior installation CP510

In polyester
540 L x 520 H x 240 D mm +580 mm base height
For installing a 1- or 2-pump electrical box

Cable extension kit including:

- 1 connection for 2 single-phase and triple-phase pumps and 1 alarm float.
 - 1 connection for piezo probe
- To be installed in a manhole or in the unit

Contact Us



Anchoring kit

OSE73050

3 steel components
Composed of a tank attaching bracket and a welded steel mesh, the kit facilitates anchoring the tank in case of groundwater.
Weight: 8.5 kg

Non-contractual texts, dimensions, photos and diagrams

SMALL RESIDENTIAL BLOCK





Pumping stations
for use in
**residential
blocks**

- Star 1000** 2 Dn50 pumps on foot brackets __ p.26-27
- Star 1000** 2 Dn65 pumps on foot brackets __ p.28-29
- Star 1200R** 2 Dn50 pumps on foot brackets
with integrated valve chamber _____ p.30-31
- Star 1200R** 2 Dn65 pumps on foot brackets
with integrated valve chamber _____ p.32-33
- Srt 10** 2 Dn50 pumps on foot brackets _____ p.34-35
- Srt 10** 2 Dn65 pumps on foot brackets _____ p.36-37
- Srt 10** 2 Dn50 pumps on foot brackets
with integrated valve chamber _____ p.38-39
- Srt 10** 2 Dn65 pumps on foot brackets
with integrated valve chamber _____ p.40-41



STAR1000 Dn50

2 pumps on foot brackets



Commissioning:
contact us

Height 2.50 m
PUE25P2DN050T

Height 2 m
PUE20P2DN050T

Design

- Polyethylene corrosion-proof tank. Built with reinforced braces for better mechanical resistance,
- Usable sub-inlet volume: 640 L,
- Lockable non-slip cover for safe installation under landscaped areas,
- Female PVC sealing entry sleeve for exterior Ø 200 PVC pipe,
- Ext. Ø63 bonding PVC pressure outlet pipe,
- Female Ø 100/117 PVC sealing ventilation sleeve with stopper for exterior Ø 100 PVC pipe,
- 2 Ø 76/90 TPC cable gland sheaths,
- Handling straps for easy installation.

Interior equipment

- 2 submerged pumps,
- Composite foot bracket system and guiding bars made of composite material (2 m tall) or stainless steel (2.5 m tall): Easy pump installation,
- 2 Dn50 PVC discharge pipes,
- 2 PVC ball valves and 2 Dn50 cast-iron non-return ball valves attached on unions,
- 1 alarm float (10 m),
- 1 piezo probe attached to a chain with a counterweight (10-metre cable),
- Polyethylene frame for holding the screen basket.
- **Fall protection grill, stainless steel grill for 740 mm diameter polyethylene opening.**

IL Star 1000,
2 metres tall:
standard 1200 mm

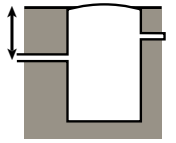

Upon request
from 800 to 1300 mm

IL Star 1000,
2.5 meters tall:
standard 1700 mm

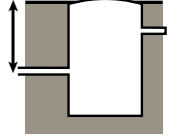

Upon request
from 1300 to 1700 mm

Non-contractual texts, dimensions, photos and diagrams

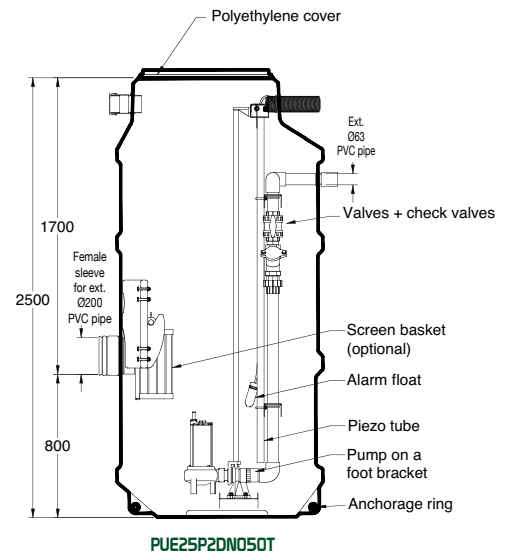
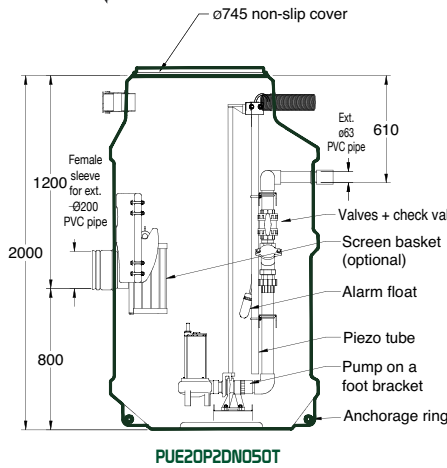
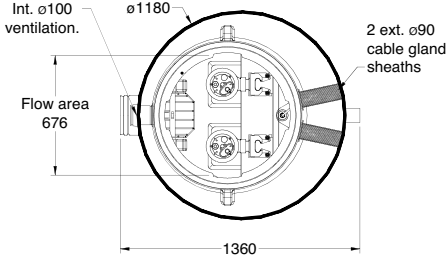

For our STAR 1000 models, selecting your pumping station is done in 3 steps:

1 Tank choice



2 Pump choice



3 Electrical box choice

Tank reference	Ø Inlet (mm)	Ø Outlet (mm)	Weight (kg)
PUE20P2DN050T	For ext. Ø 200 PVC pipe	Ext. Ø 63 pressure PVC pipe	140
PUE25P2DN050T		Ext. Ø 63 pressure PVC pipe	179

Pump reference	Curve/pump No.	Flowarea (mm)	Amperage (amps)	Voltage (volts)	Power (kW)	Box reference
PJS0590M	17	50	10.5	230 V single	1.5	CSJ209
PJS0590T			4.1	400 V triple		CSJ204

STAR1000 Dn50



The pumps



230 v single-phase with capacitor integrated into the box or 400 V triple-phase.

Construction: pump housing and cast-iron Vortex wheel, stainless steel engine cover,

Protection: IP68, insulation class F.

Temperature of liquids: +50°C max.,

Use: Particle-laden water.

Flow area: 50 mm.

Discharge: 2".

Equipped with a 10-metre cable and **2 wires for isotherm**

Weight: 18.2 kg.

Model selection based on flow rate and Total Head (TDH). If you do not know which one to select, refer to page 45 to calculate the flow rate and TDH.

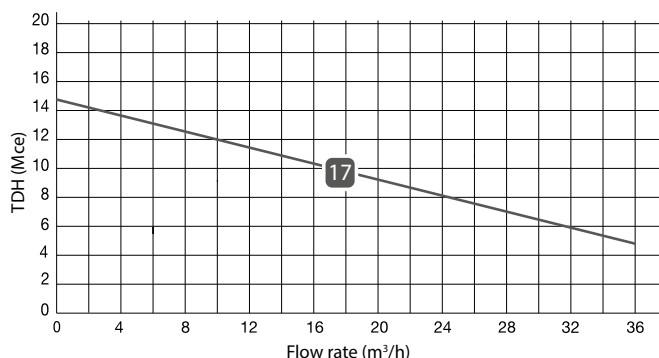

17 PJS0590M or T SEMISOM 590 M or T

The box and the probe



Piezo probe (10-metre cable)



Technical features

- **230 Volt single-phase or 400 volt four-phase + neutral wiring.**
- Automatic pump starts depending on the tank level.
- Automatic reverse at each start.
- Sound and visual alarm on alarm float.
- Lockable disconnecter.
- Push-button Force Start function on pumps.
- For 230 V pumps: capacitor integrated into the box
- On/Off indicator display per pump.
- Dry contact for alarm transfer.
- **Volume:** **278 L x 130 D x 378 H mm**

For more info, see page 46

Options

Cover extensions

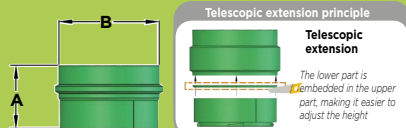

After the second stacked extension, a concrete slab is necessary. The unit should be installed as shallow as possible to make its servicing easier and avoid ground overload on the tank.

References	A (mm)	B (mm)	Weight (kg)	Telescopic	Fall protection grill
ETR47EF	490	780	10.5 kg	•	•
ETR65EF	650	780	18 kg	•	•



Aluminium screen basket

With handling chain.
Basket dimensions: 245 L x 215 D x 400 H mm. Weight: 2.9 kg.

OS530



50 kg folding gallow

Conforming with machine directive 2006/42/EC. Declaration of conformity upon delivery. Suitability for use assessment to performed for permanent installation

OS096

50 kg, galvanised steel folding gallow with hoist and galvanised steel gallow brace. The gallow is moveable and can be folded up for easy transport. Weight 17 kg.



Cabinet with base for exterior installation

In polyester. Dimensions: 540 L x 520 H x 240 D mm + 580 mm base height
For installing a 1- or 2-pump electrical box

CP510

Cable extension kit including:

- 1 connection for 2 single-phase and triple-phase pumps and 1 alarm float,
 - 1 connection for piezo probe.
- To be installed in a manhole or in the unit

Contact Us



Anchoring kit

4 steel components
Composed of a tank attaching bracket and a welded steel mesh, the kit facilitates anchoring the tank amid groundwater. Weight: 11.5 kg.

OSE73060

Non-contractual texts, dimensions, photos and diagrams

RESIDENTIAL BLOCK



STAR1000 Dn50

2 pumps on foot brackets



Design

- Polyethylene corrosion-proof tank. Built with reinforced braces for better mechanical resistance,
- Usable sub-inlet volume: 640 L,
- Lockable non-slip cover for safe installation under landscaped areas,
- Female PVC sealing entry sleeve for exterior Ø 200 PVC pipe,
- Ext. Ø 75 bonding PVC pressure outlet pipe,
- Female Ø 100/117 PVC sealing ventilation sleeve with stopper for exterior Ø 100 PVC pipe,
- 2 Ø 76/90 TPC cable gland sheaths,
- Handling straps for easy installation.

Interior equipment

- 2 submerged pumps,
- Cast-iron foot bracket system and stainless steel guiding bars (easier pump installation),
- 2 Dn65 PVC discharge pipes,
- 2 PVC ball valves and 2 Dn65 cast-iron non-return ball valves attached on unions,
- 1 alarm float (10 m),
- 1 piezo probe attached to a chain with a counterweight (10-metre cable),
- Polyethylene frame for holding the screen basket.
- **Fall protection grill, stainless steel grill for 740 mm diameter polyethylene opening.**

IL Star 1000,
2 metres tall:
standard 1200 mm

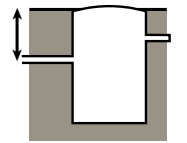

Upon request
from 800 to 1300 mm

IL Star 1000,
2.5 meters tall:
standard 1700 mm

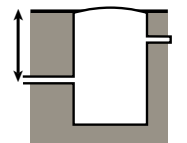

Upon request
from 1300 to 1700 mm

*Commissioning:
contact us*



Height 2.50 m
PUE25P2DN065T

Height 2 m
PUE20P2DN065T



Non-contractual texts, dimensions, photos and diagrams

RESIDENTIAL BLOCK

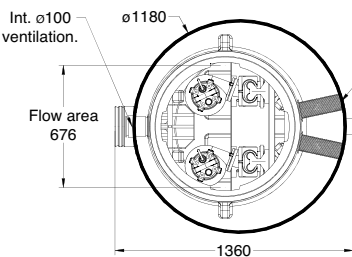

2 ext. ø90 cable gland sheaths

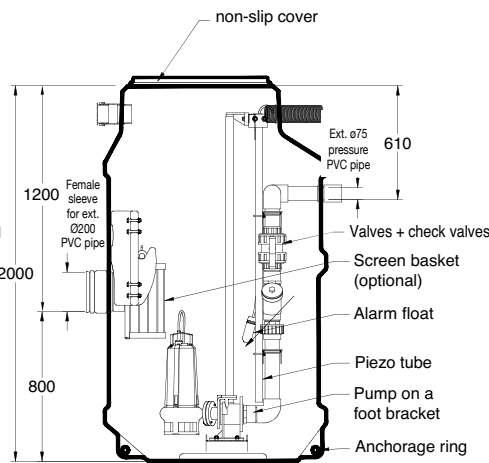

PUE20P2DN065T

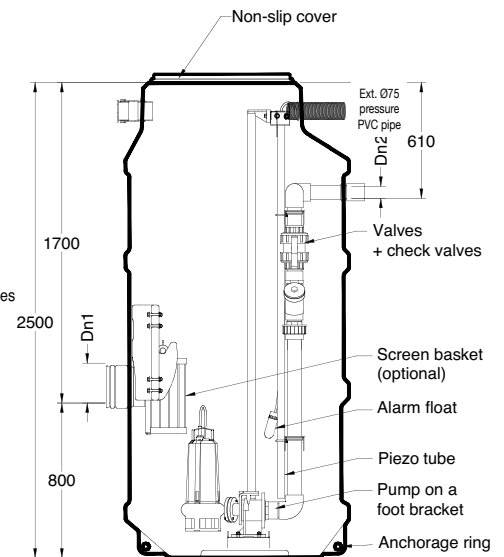

PUE25P2DN065T



For our STAR 1000 models, selecting your pumping station is done in 3 steps:

1 Tank choice



2 Pump choice



3 Electrical box choice

Tank reference	Ø Inlet (mm)	Ø Outlet (mm)	Weight (kg)
PUE20P2DN065T	For ext. Ø 200 PVC pipe	Ext. Ø 75 PVC pressure pipe	168
PUE25P2DN065T			207

Pump reference	Curve/pump No.	Flowarea (mm)	Amperage (amps)	Voltage (volts)	Power (kW)	Box reference
PJS0650T	03	65	4.6	400 V triple	1.5	CSJ204
PJS0650HT	11	65	4.6			CSJ204
PJS1000/S0T	07	50	5.9			CSJ204
PJS0650M	03	65	12	230 V single	1.5	CSJ209
PJS0650HM	11	65	12			CSJ209

STAR1000 Dn65



The box and the probe

Technical features

- 230 Volt single-phase or 400 volt four-phase + neutral wiring.
- Automatic pump starts depending on the tank level.
- Automatic reverse at each start.
- Sound and visual alarm on alarm float.
- Lockable disconnecter.
- Push-button Force Start function on pumps.
- On/Off indicator display per pump.
- Dry contact for alarm transfer.
- Volume: 278 L x 130 D x 378 H mm

Piezo probe (10-metre cable)



For more info, see page 46

Model selection

based on flow rate and Total Head (TDH). If you do not know which one to select, refer to page 45 to calculate the flow rate and TDH.

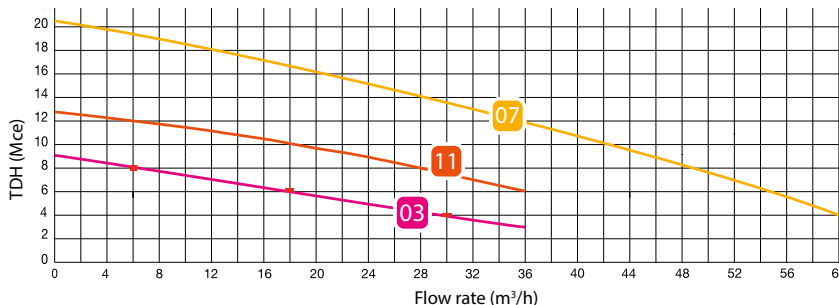

The pumps

230 V single-phase or 400 V triple-phase

Construction:

cast-iron pump housing and steel engine cover,

Temperature of liquids:

+50°C max.,

Protection:

IP68, insulation class F,

Use:

particle-laden liquid,

Discharge:

Equipped with a 10-metre cable and 2 wires for isotherm



SPECIFICALLY ADAPTED TO PUBLIC AREAS
NON-CLOGGING
Cast-iron Vortex wheel,
Weight: 21 kg.

03 PJS0650M or T SEMISOM 650 M or T

11 PJS0650H M or T SEMISOM 650 H M or T



Cast-iron double-channel impeller,
Weight: 39.4 kg.

07 PJS1000/50T SEMISOM 1000/50 T

Options

Cover extensions

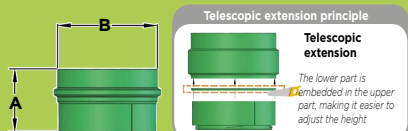

After the second stacked extension, a concrete slab is necessary. The unit should be installed as shallow as possible to make its servicing easier and avoid ground overload on the tank,

References	A (mm)	B (mm)	Weight (kg)	Telescopic	Fall protection grill
ETR47EF	490	780	10.5 kg	•	GI0670I
ETR65EF	650	780	18 kg	•	



Aluminium screen basket

With handling chain.
Basket dimensions: 245 L x 215 D x 400 H mm. Weight: 2.9 kg.

OS530



50 kg folding gallow

Conforming with machine directive 2006/42/EC. Declaration of conformity upon delivery. Suitability for use assessment to be performed for permanent installation

50 kg, galvanised steel folding gallow with hoist and galvanised steel gallow brace. The gallow is moveable and can be folded up for easy transport. Weight 17 kg.

OS096



Cabinet with base for exterior installation

In polyester. Dimensions: 540 L x 520 H x 240 D mm + 580 mm base height
For installing a 1- or 2-pump electrical box

CP510

Cable extension kit

- including:
- 1 connection for 2 single-phase and triple-phase pumps and 1 alarm float,
 - 1 connection for piezo probe.
- To be installed in a manhole or in the unit

Contact Us



Anchoring kit

4 steel components
Composed of a tank attaching bracket and a welded steel mesh, the kit facilitates anchoring the tank amid groundwater. Weight: 11.5 kg.

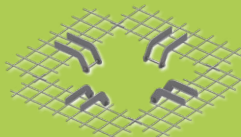

Non-contractual texts, dimensions, photos and diagrams

RESIDENTIAL BLOCK



STAR_{1200R} Dn50

2 pumps on foot brackets, with valve chamber

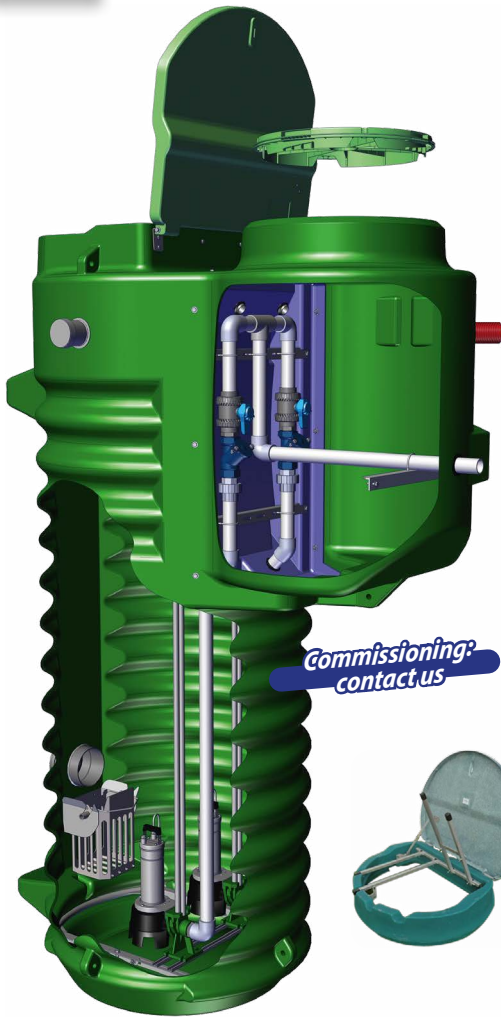

Design

- High mechanical resistance polyethylene, corrosion-proof tank,
- Integrated polyethylene valve chamber,
- Usable sub-inlet volume: 870 L,
- 1 lockable, hinged, polyester cover with cover stay,
- 1 cover, 6800 mm diameter, with quarter-turn closure and locking screw,
- Female PVC sealing entry sleeve for exterior Ø 200 PVC pipe,
- Ext. Ø 63 PVC bonding pressure outlet pipe,
- Female Ø 100 PVC sealing ventilation sleeve with stopper,
- 2 Ø 76/90 TPC cable gland sheaths,
- Handling straps for easy installation.

Interior equipment

- 2 submerged pumps,
- Composite foot bracket system and stainless steel guiding bars: easier pump installation,
- 2 certified pump hoisting chains
- 2 interior Ø 50 PVC pressure discharge pipes.
- 1 stainless steel support (for screen baskets 2.5 m to 3.5 m tall),
- 1 piezo probe (10-metre cable) and 1 alarm float (10-metre cable) attached to a chain with counterweight,

> Chamber-specific equipment:

- 2 PVC ball valves and 2 int. Dn50 cast-iron non-return ball valves, all attached on 3 unions
- 1 PVC U-bend connection.
- **Fall protection grill for the lifting well, safety guarantee during maintenance operations. Independent 304 stainless steel bars.**

Product advantages

The integrated valve chamber greatly simplifies installation and prevents pipe connection difficulties.
All metallic components are made of stainless steel

Non-contractual texts, dimensions, photos and diagrams

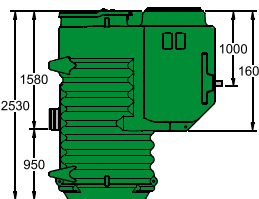
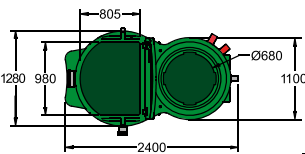

PURE25P2DN050T

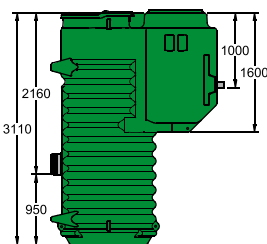

PURE30P2DN050T

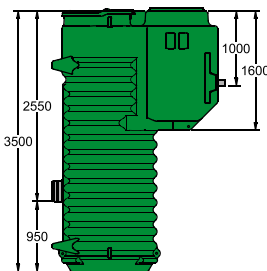

PURE35P2DN050T

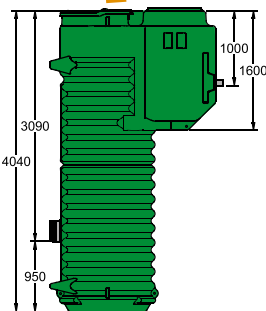

PURE40P2DN050T

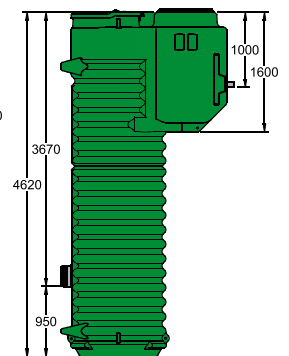

PURE45P2DN050T



For our STAR 1200R models, selecting your pumping station is done in 3 steps:

1 Tank choice



2 Pump choice



3

Electrical box choice

Tank reference	Weight (kg)	Ø Inlet (mm)	Ø Outlet (mm)
PURE25P2DN050T	260	Female sleeve for ext. Ø 200 PVC pipe	Ext. Ø 63 PVC bonding pressure outlet pipe
PURE30P2DN050T	290		
PURE35P2DN050T	310		
PURE40P2DN050T	345		
PURE45P2DN050T	376		

Pump reference	Curve/pump No.	Flow area (mm)	Amperage (amps)	Voltage (volts)	Power (kW)	Box reference
PJS0590M	17	50	10.5	230 V single	1.5	CSJ209
PJS0590T			4.1	400 V triple		CSJ204

STAR1200R Dn50



The pumps



230 v single-phase with capacitor integrated into the box or 400 V triple-phase.

Construction: pump housing and cast-iron Vortex wheel, stainless steel engine cover,

Protection: IP68, insulation class F.

Temperature of liquids: +50°C max.,

Use: Particle-laden water.

Flow area: 50 mm.

Discharge: 2".

Equipped with a 10-metre cable and **2 wires for isotherm**

Weight: 18.2 kg.

Model selection

based on flow rate and Total Head (TDH). If you do not know which one to select, refer to page 45 to calculate the flow rate and TDH.

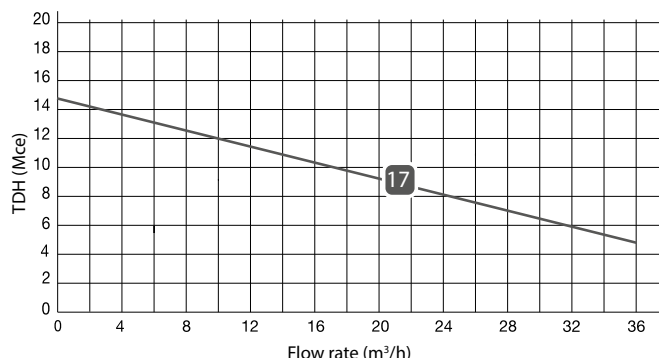

17

PJS0590M or T

SEMISOM 590 M or T

The box and the probe



Piezo probe (10-metre cable)



Technical features

- 230 Volt single-phase or 400 volt four-phase + neutral wiring.
- Automatic pump starts depending on the tank level.
- Automatic reverse at each start.
- Sound and visual alarm on alarm float.
- Lockable disconnector.
- Push-button Force Start function on pumps.
- On/Off indicator display per pump.
- Dry contact for alarm transfer.
- **Volume:** 278 L x 130 D x 378 H mm

For more info, see page 46

Options



Screen basket on support

With handling chain.
Basket dimensions: Width 245 mm x Depth 215 mm x Height 400 mm.
Weight 2.9 kg.

OS590

For units 2.5 m to 3.5 m tall



50 kg folding gallow

50 kg, galvanised steel folding gallow with hoist and galvanised steel gallow brace. The gallow is moveable and can be folded up for easy transport (weight 17 kg).



Conforming with machine directive 2006/42/EC. Declaration of conformity upon delivery. Suitability for use assessment to be performed for permanent installation

OS101



Guiding bar-mounted aluminium screen basket

With handling chain.
Basket dimensions: Width 270 mm x Depth 120 mm x Height 400 mm 4.9 kg.

OS595

For units 4 m to 4.5 m tall



Cabinet with base for exterior installation

In polyester. Dimensions: 540 L x 520 H x 240 D mm + 580 mm base height
For installing a 1- or 2-pump electrical box

CP510

Anchoring kit

OSE73050

Components made up of a tank attaching bracket and welded steel mesh. This kit facilitates anchoring the tank amid groundwater.
2 steel components for the tank.

1 steel component for the valve chamber.
Unit weight: 8.5 kg.

Cable extension kit including:

- 1 connection for 2 single-phase and triple-phase pumps and 1 alarm float,
 - 1 connection for piezo probe.
- To be installed in a manhole or in the unit

Contact Us



Non-contractual texts, dimensions, photos and diagrams

RESIDENTIAL BLOCK



STAR_{1200R}

2 pumps on foot brackets, with valve chamber Dn65



Design

- High mechanical resistance polyethylene, corrosion-proof tank,
- Integrated polyethylene valve chamber,
- Usable sub-inlet volume: 870 L,
- 1 lockable, hinged, polyester cover, with cover stay,
- 1 cover, 6800 mm diameter, with quarter-turn closure and locking screw,
- Female PVC sealing entry sleeve for exterior Ø 200 PVC pipe,
- Ext. Ø 75 PVC bonding pressure outlet pipe,
- Female Ø 100 PVC sealing ventilation sleeve with stopper,
- 2 Ø 76/90 TPC cable gland sheaths,
- Handling straps for easy installation.

Interior equipment

- 2 submerged pumps,
 - Cast-iron bracket system and stainless steel guiding bars: easier pump installation,
 - 2 certified pump hoisting chains
 - 2 interior Ø 63 PVC pressure discharge pipes.
 - 1 stainless steel support (for screen baskets 2.5 m to 3.5 m tall),
 - 1 piezo probe (10-metre cable) and 1 alarm float (10-metre cable) attached to a chain with counterweight,
- > Chamber-specific equipment:**
- 2 PVC ball valves and 2 int. Dn65 cast-iron non-return ball valves, all attached on 3 unions
 - 1 PVC U-bend connection.
- Fall protection grill for the lifting well, safety guarantee during maintenance operations. Independent 304 stainless steel bars.**

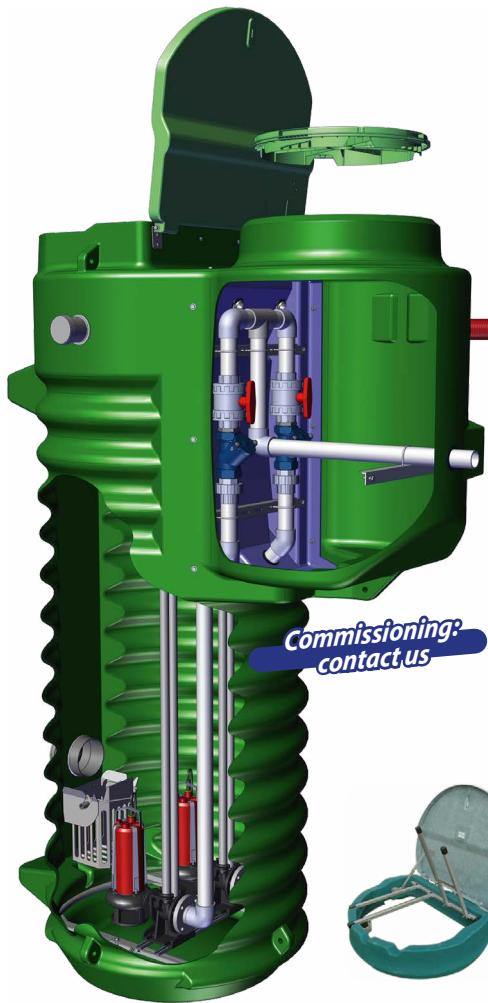

Product advantages

The integrated valve chamber greatly simplifies installation and prevents pipe connection difficulties.

All metallic components are made of stainless steel

RESIDENTIAL BLOCK

Non-contractual texts, dimensions, photos and diagrams

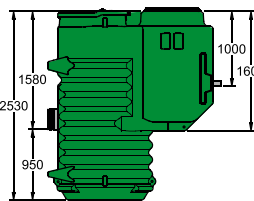
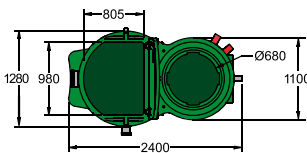

PURE25P2DN065T

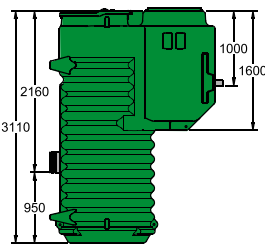

PURE30P2DN065T

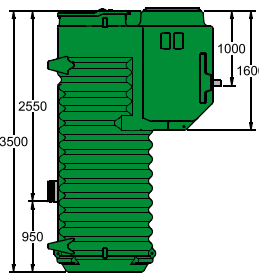

PURE35P2DN065T

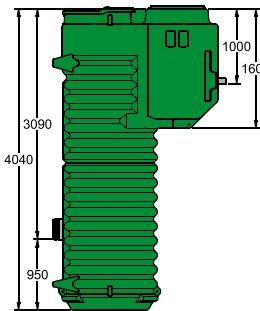

PURE40P2DN065T

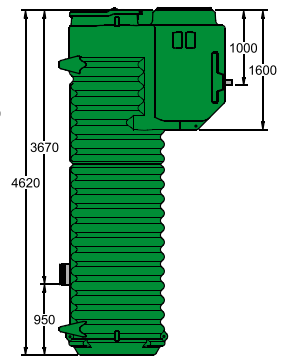

PURE45P2DN065T



For our STAR 1200R models, selecting your pumping station is done in **3** steps:

1 Tank choice



2 Pump choice



3 Electrical box choice

Tank reference	Weight (kg)	Ø Inlet (mm)	Ø Outlet (mm)
PURE25P2DN065T	283	Female sleeve for ext. Ø 200 PVC pipe	Ext. Ø 75 PVC bonding pressure outlet pipe
PURE30P2DN065T	314		
PURE35P2DN065T	336		
PURE40P2DN065T	373		
PURE45P2DN065T	403		

Pump reference	Curve/pump No.	Flowarea (mm)	Amperage (amps)	Voltage (volts)	Power (kW)	Box reference
PJS0650T	03	65	4.6	Triple 400 V single	1.5	CSJ204
PJS0650HT	11	65	4.6			CSJ204
PJSI000/50T	07	50	5.9			CSJ204
PJS0650M	03	65	12	Single 230 V single	1.5	CSJ209
PJS0650HM	11	65	12			CSJ209

STAR1200R Dn65



The box and the probe

Technical features

- 230 Volt single-phase or 400 volt four-phase + neutral wiring.
 - Automatic pump starts depending on the tank level.
 - Automatic reverse at each start.
 - Sound and visual alarm on alarm float.
 - Lockable disconnecter.
 - Push-button Force Start function on pumps.
 - On/Off indicator display per pump.
 - Dry contact for alarm transfer.
- Volume:**
278 L x 130 D x 378 H mm

Piezo probe (10-metre cable)



For more info, see page 46

Model selection based on flow rate and Total Head (TDH). If you do not know which one to select, refer to page 45 to calculate the flow rate and TDH.

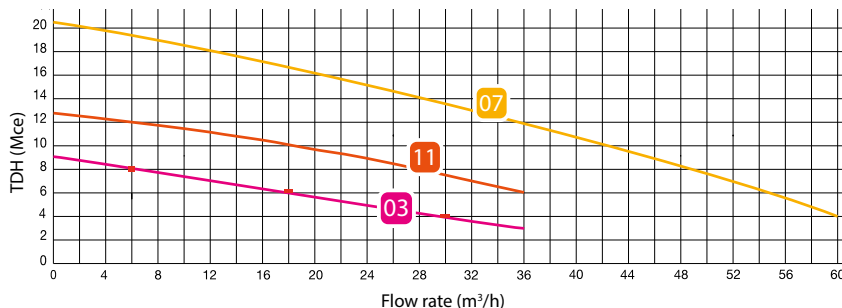

The pumps

230 V single-phase or 400 V triple-phase

Construction:

cast-iron pump housing, steel engine cover,

Temperature of liquids:

+50°C max.,

Protection: IP68, insulation class F,

Use: particle-laden liquid,

Discharge: 2" 1/2,

Equipped with a 10-metre cable and 2 wires for isotherm



SPECIFICALLY ADAPTED TO PUBLIC AREAS
NON-CLOGGING

Cast-iron Vortex wheel,
Weight: 21 kg.

- 03** PJS0650M or T SEMISOM 650 M or T
- 11** PJS0650 H M or T SEMISOM 650 H M or T



Cast-iron double-channel impeller,
Weight: 39.4 kg.

- 07** PJS1000/50T SEMISOM 1000/50 T

Options



Support-mounted aluminium screen basket

OS590

With handling chain.
Basket dimensions:
Width 245 mm x Depth 215 mm x Height 400 mm.
Weight 2.9 kg.

For units 2.5 m to 3.5 m tall



50 kg folding gallow



Conforming with machine directive 2006/42/EC. Declaration of conformity upon delivery. Suitability for use assessment to be performed for permanent installation

50 kg, galvanised steel folding gallow with hoist and galvanised steel gallow brace. The gallow is moveable and can be folded up for easy transport (weight 17 kg).

OS101



Guiding bar-mounted aluminium screen basket

OS595

With handling chain.
Basket dimensions:
Width 270 mm x Depth 120 mm x Height 400 mm 4.9 kg.

For units 4 m to 4.5 m tall



Cabinet with base for exterior installation

CP510

In polyester. Dimensions: 540 L x 520 H x 240 D mm + 580 mm base height
For installing a 1- or 2-pump electrical box

Anchoring kit

OSE73050

Components made up of a tank attaching bracket and welded steel mesh. This kit facilitates anchoring the tank amid groundwater.

2 steel components for the tank.
1 steel component for the valve chamber.
Unit weight: 8.5 kg.

Cable extension kit including:

- 1 connection for 2 single-phase and triple-phase pumps and 1 alarm float,
 - 1 connection for piezo probe.
- To be installed in a manhole or in the unit

Contact Us



Non-contractual texts, dimensions, photos and diagrams

RESIDENTIAL BLOCK



SRT10

2 pumps on foot brackets, Dn50



Displayed model
PUP30P2DN050T

Design

- High mechanical resistance polyester, corrosion-proof tank,
- Usable sub-inlet volume: 566 L,
- 1 polyethylene baseplate for round cover
- 1 D740 polyester cover with seal and quarter-turn opening /closing with locking screw.
- Ext. Ø 200 PVC pipe inlet – delivered with flexible adaptation sleeve
- Ext. Ø 63 PVC bonding pressure outlet pipe,
- Female Ø 100/117 PVC sealing ventilation sleeve with stopper for exterior Ø 100 PVC pipe,
- 2 Ø 76/90 TPC cable gland sheaths,
- Lift loops
- Other dimensions upon request. Contact our design office.

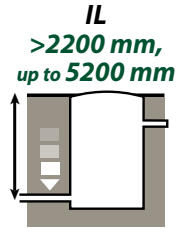

Commissioning:
contact us

Interior equipment

- 2 submerged pumps,
- Composite foot bracket system and stainless steel guiding bars (easier pump installations),
- 2 Dn50 PVC discharge pipes,
- 2 PVC valves and 2 cast-iron non-return ball valves Dn50 attached to expansion compensators
- 1 stainless steel brace (unit height ≤ 3.5 m) for screen basket option,
- 1 alarm float (10-metre cable),
- 1 piezo probe attached to a chain with counterweight (10-metre cable).
- **Fall protection grill for the lifting well, safety guarantee during maintenance operations. Independent 304 stainless steel bars.**

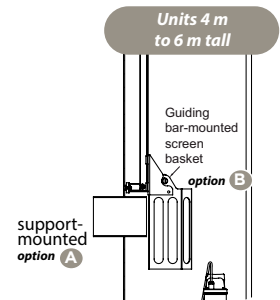

Product advantages

Anchoring flange directly integrated into the tank.

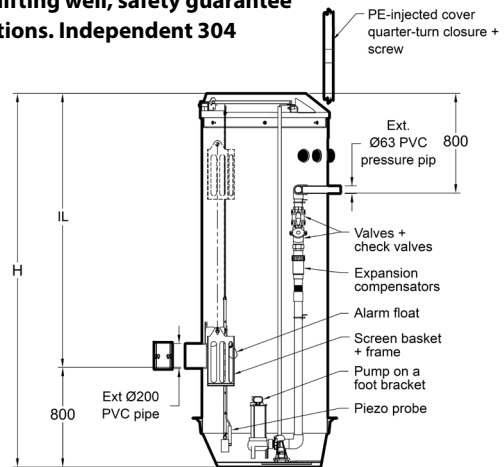
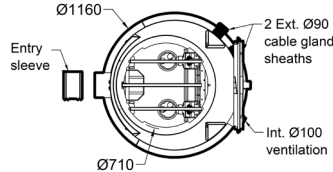

Non-contractual texts, dimensions, photos and diagrams

For our SRT 10 models, selecting your pumping station is done in 3 steps:

1 Tank choice

+ 2

Pump choice

+ 3

Electrical box choice

Tank reference	H Height (mm)	Weight (kg)	(IL) (mm)	Ø Inlet (mm)	Ø Outlet (mm)
PUP30P2DN050T	3000	198	2200	Ext. Ø 200 PVC pipe.	Ext. Ø 63 PVC pressure pipe
PUP35P2DN050T	3500	216	2700		
PUP40P2DN050T	4000	234	3200		
PUP45P2DN050T	4500	251	3700		
PUP50P2DN050T	5000	269	4200		
PUP55P2DN050T	5500	287	4700		
PUP60P2DN050T	6000	305	5200		

Pump reference	Curve/pump No.	Flow area (mm)	Amperage (amps)	Voltage (volts)	Power (kW)	Box reference
PJS0590M	17	50	10.5	230 V single	1.5	CSJ209
PJS0590T			4.1	400 V triple		CSJ204

Other Inlet Levels (IL) upon request: Contact our design office.

SRT10 Dn50



The pumps



230 v single-phase with capacitor integrated into the box or 400 V triple-phase.

Construction: pump housing and cast-iron Vortex wheel, stainless steel engine cover,

Protection: IP68, insulation class F.

Temperature of liquids: +50°C max.,

Use: Particle-laden water.

Flow area: 50 mm.

Discharge: 2".

Equipped with a 10-metre cable and **2 wires for isotherm**

Weight: 18.2 kg.

Model selection

based on flow rate and Total Head (TDH). If you do not know which one to select, refer to page 45 to calculate the flow rate and TDH.

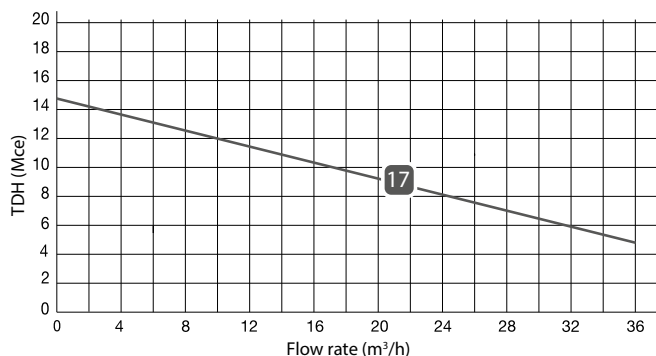

17

PJS0590M or T

SEMISOM 590 M or T

The box and the probe



Piezo probe (10-metre cable)



Technical features

- **230 Volt single-phase or 400 volt four-phase + neutral wiring.**
- Automatic pump start depending on the tank level.
- Automatic reverse at each start.
- Sound and visual alarm on alarm float.
- Lockable disconnecter.
- Push-button Force Start function on pumps.
- On/Off indicator display per pump.
- Dry contact for alarm transfer.
- **Volume:** **278 L x 130 D x 378 H mm**

For more info, see page 46

Options



Support-mounted aluminium screen basket ^A

OS535

For units 3 m and 3.5 m tall. With handling chain. Width 245 mm x Depth 215 mm x Height 400 mm. Weight 2.9 kg.



50 kg folding gallow



Conforming with machine directive 2006/42/EC. Declaration of conformity upon delivery. Suitability for use assessment to be performed for permanent installation

50 kg, galvanised steel folding gallow with hoist and galvanised steel gallow brace. The gallow is moveable and can be folded up for easy transport (weight 17 kg).

OS101



Guiding bar-mounted aluminium screen basket ^B

with handling chain. Width 280 mm x Depth 120 mm x Height 400 mm. Weight: 4.9 kg.

For units 4 m to 5 m tall DS2001050A

For units 5 m to 6 m tall DS2001070A



Cabinet with base for exterior installation

CP510

In polyester. Dimensions: 540 L x 520 H x 240 D mm + 580 mm base height
For installing a 1- or 2-pump electrical box

Cable extension kit including:

- 1 connection for 2 single-phase and triple-phase pumps and 1 alarm float,
- 1 connection for piezo probe. To be installed in a manhole or in the unit

Contact Us



Non-contractual texts, dimensions, photos and diagrams

RESIDENTIAL BLOCK



SRT10 2 pumps on foot brackets, Dn65



Design

- High mechanical resistance polyester, corrosion-proof tank,
- Usable sub-inlet volume: 566 L,
- 1 polyethylene baseplate for round cover,
- D740 polyester cover with seal and quarter-turn opening / closing with locking screw.
- Ext $\varnothing 200$
PVC pipe entrance – delivered with flexible adaptation sleeve
- Ext. $\varnothing 75$ PVC bonding pressure outlet pipe,
- Female $\varnothing 100/117$ PVC sealing ventilation sleeve with stopper for exterior $\varnothing 100$ PVC pipe,
- 2 $\varnothing 76/90$ TPC cable gland sheaths,
- Lift loop
- Other dimensions upon request. Contact us.

IL
>2200 mm,
up to 5200 mm

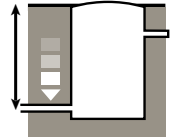

**Commissioning:
contact us**



Displayed model
PUP30P2DN065T

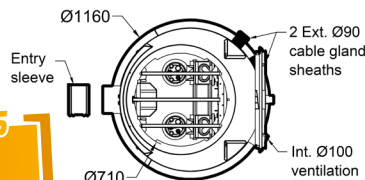

Interior equipment

- 2 submerged pumps,
- Cast-iron bracket system and stainless steel guiding bars (easier pump installation),
- 2 Dn65 PVC discharge pipes,
- 2 PVC ball valves and 2 Dn65 cast-iron non-return ball valves attached to expansion compensators
- 1 stainless steel brace (unit height. ≤ 3.5 m) for screen basket option,
- 1 alarm float (10-metre cable)
- 1 piezo probe attached to a chain with counterweight (10-metre cable).
- **Fall protection grill for the lifting well, safety guarantee during maintenance operations. Independent 304 stainless steel bars.**

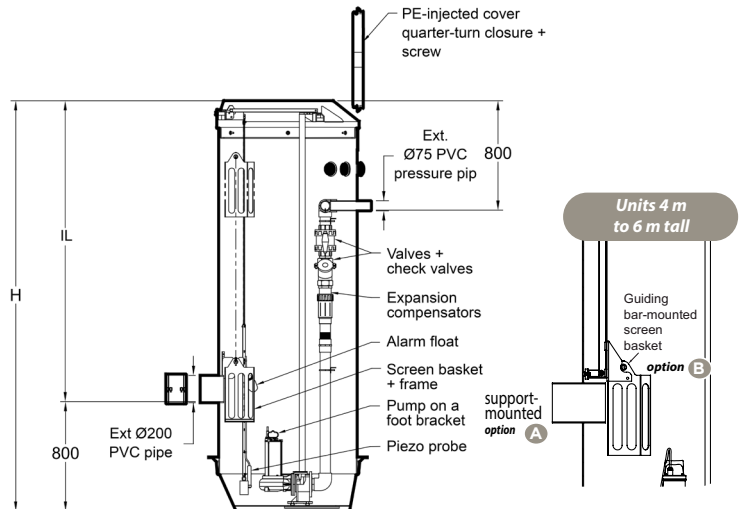

Non-contractual texts, dimensions, photos and diagrams

Product advantages

Anchoring flange
Directly integrated
Into the tank.



For our SRT 10 models, selecting your pumping station is done in **3 steps**:

1 Tank choice



2 Pump choice



3 Electrical box choice

Tank reference	H Height (mm)	Weight (kg)	(IL) (mm)	\varnothing Inlet (mm)	\varnothing Outlet (mm)
PUP30P2DN065T	3000	251	2200	Ext. \varnothing 200 PVC pipe.	Ext. \varnothing 75 PVC pressure pipe
PUP35P2DN065T	3500	269	2700		
PUP40P2DN065T	4000	286	3200		
PUP45P2DN065T	4500	304	3700		
PUP50P2DN065T	5000	322	4200		
PUP55P2DN065T	5500	340	4700		
PUP60P2DN065T	6000	358	5200		

Pump reference	Curve/pump No.	Flowarea (mm)	Amperage (amps)	Voltage (volts)	Power (kW)	Box reference
PJS0650T	03	65	4.6	Triple 400 V single	1.5	CSJ204
PJS0650HT	11	65	4.6			
PJS1000/50T	07	50	5.9			
PJS0650M	03	65	12	Single 230 V single	1.5	CSJ209
PJS0650HM	11	65	12			

Other Inlet Levels (IL) upon request: Contact our design office.

SRT10 Dn65



The box and the probe

Technical features

- 230 Volt single-phase or 400 volt four-phase + neutral wiring.
- Automatic pump start depending on the tank level.
- Automatic reverse at each start.
- Sound and visual alarm on alarm float.
- Lockable disconnecter.
- Push-button Force Start function on pumps.
- On/Off indicator display per pump.
- Dry contact for alarm transfer.
- Volume: 278 L x 130 D x 378 H mm

Piezo probe (10-metre cable)



For more info, see page 46

Model selection based on flow rate and Total Head (TDH).

If you do not know which one to select, refer to page 45 to calculate the flow rate and TDH.

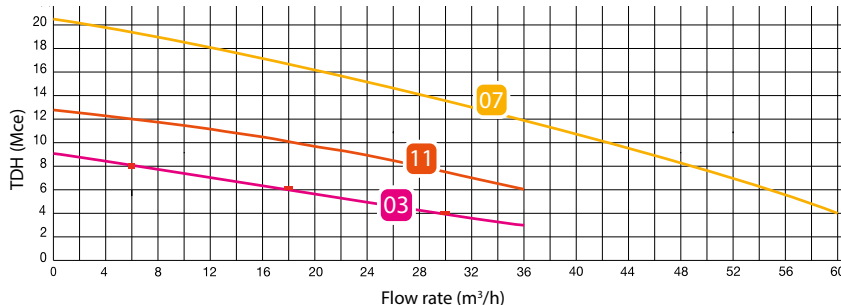

The pumps

230 V single-phase or 400 V triple-phase

Construction: cast-iron pump housing and steel engine cover,

Temperature of liquids: +50°C max.,

Protection: IP68, insulation class F,

Use: particle-laden liquid,

Discharge: 2" 1/2, Equipped with a 10-metre cable and 2 wires for isotherm



SPECIFICALLY ADAPTED TO PUBLIC AREAS
NON-CLOGGING

Cast-iron Vortex wheel,
Weight: 21 kg.

03 PJS0650M or T SEMISOM 650 M or T

11 PJS0650H M or T SEMISOM 650 H M or T



Cast-iron double-channel impeller,
Weight: 39.4 kg.

07 PJS1000/50T SEMISOM 1000/50 T

Options



Support-mounted aluminium screen basket **A**

OS535

For units 3 m and 3.5 m tall. With handling chain. Width 245 mm x Depth 215 mm x Height 400 mm. Weight 2.9 kg.



50 kg folding gallow



Conforming with machine directive 2006/42/EC. Declaration of conformity upon delivery. Suitability for use assessment to be performed for permanent installation

50 kg, galvanised steel folding gallow with hoist and galvanised steel gallow brace. The gallow is moveable and can be folded up for easy transport (weight 17 kg).

OS101



Guiding bar-mounted aluminium screen basket **B**

with handling chain. Width 280 mm x Depth 120 mm x Height 400 mm. Weight: 4.9 kg.

For units 4 m to 5 m tall **DS2001050A**

For units 5 m to 6 m tall **DS2001070A**



Cabinet with base for exterior installation

CP510

In polyester. Dimensions: 540 L x 520 H x 240 D mm + 580 mm base height
For installing a 1- or 2-pump electrical box

Cable extension kit including:

- 1 connection for 2 single-phase and triple-phase pumps and 1 alarm float,
- 1 connection for piezo probe. To be installed in a manhole or in the unit

Contact Us



Non-contractual texts, dimensions, photos and diagrams

RESIDENTIAL BLOCK



SRV10 2 pumps on foot brackets, Dn50 with valve chamber



IL
>2200 mm,
up to 5200 mm



Interior equipment

> Tank-specific equipment:

- 2 submerged pumps,
- Composite foot bracket system and stainless steel guiding bars (easier pump installation),
- 2 Dn50 PVC discharge pipes,
- 1 stainless steel brace (unit height. ≤ 3.5 m) for screen basket option,
- 1 alarm float (10-metre cable), and 1 piezo probe attached to chain with counterweight (10-metre cable).
- **Fall protection grill for the lifting well, safety guarantee during maintenance operations. Independent 304 stainless steel bars.**

> Chamber-specific equipment:

- 2 cast-iron adapter-fittings,
- 1 valve chamber/unit drip-return pipe,
- 2 Dn50 PVC ball valves and 2 cast-iron Dn50 non-return ball valves attached to unions,
- 1 PVC U-bend connection.

Product advantages

Easily serviced:
Direct access to the unit's valves and check valves via the manhole cover

Design

- High mechanical resistance polyester, corrosion-proof tank and valve chamber,
- Usable sub-inlet volume: 566 L,
- Polyethylene baseplate for round cover
- D740 polyethylene cover with quarter-turn closure with security screw for the tanks and valve chamber.
- Ext $\varnothing 200$ PVC pipe entrance – delivered with flexible adaptation sleeve,
- Ext. $\varnothing 63$ PVC bonding pressure outlet pipe,
- Female $\varnothing 100/117$ PVC sealing ventilation sleeve with stopper for exterior $\varnothing 100$ PVC pipe ,
- 2 $\varnothing 76/90$ TPC cable gland sheaths,
- Lift loops.
- Other dimensions upon request. Contact us.

Commissioning:
contact us

Displayed model
PURP30P2DN050T

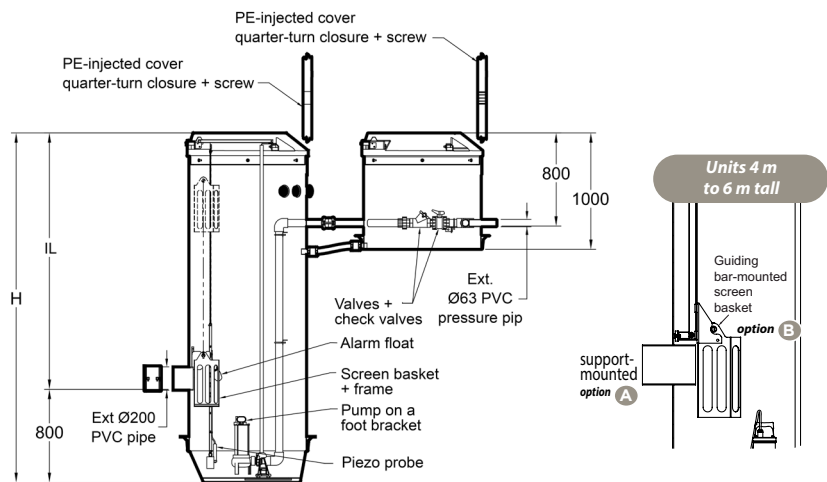
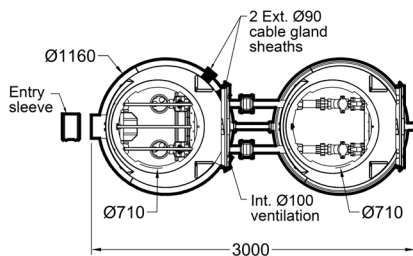

Non-contractual texts, dimensions, photos and diagrams

RESIDENTIAL BLOCK



For our SRT 10 models, selecting your pumping station is done in 3 steps:

1 Tank choice

+

2 Pump choice

+

3 Electrical box choice

Tank reference	H Height (mm)	Weight (kg)	(IL) (mm)	\varnothing Inlet (mm)	\varnothing Outlet (mm)
PURP30P2DN050T	3000	198	2200	Ext. $\varnothing 200$ PVC pipe	Ext. $\varnothing 63$ PVC pressure pipe
PURP35P2DN050T	3500	216	2700		
PURP40P2DN050T	4000	234	3200		
PURP45P2DN050T	4500	251	3700		
PURP50P2DN050T	5000	269	4200		
PURP55P2DN050T	5500	287	4700		
PURP60P2DN050T	6000	305	5200		

Pump reference	Curve/pump No.	Flow area (mm)	Amperage (amps)	Voltage (volts)	Power (kW)	Box reference
PJS0590M	17	50	10.5	230 V single	1.5	CSJ209
PJS0590T			4.1	400 V triple		CSJ204

Other Inlet Levels (IL) upon request: Contact our design office.



The pumps



230 v single-phase with capacitor integrated into the box or 400 V triple-phase.

Construction: pump housing and cast-iron Vortex wheel, stainless steel engine cover,

Protection: IP68, insulation class F.

Temperature of liquids: +50°C max.,

Use: Particle-laden water.

Flow area: 50 mm.

Discharge: 2".

Equipped with a 10-metre cable and **2 wires for isotherm**

Weight: 18.2 kg.

Model selection

based on flow rate and Total Head (TDH). If you do not know which one to select, refer to page 45 to calculate the flow rate and TDH.

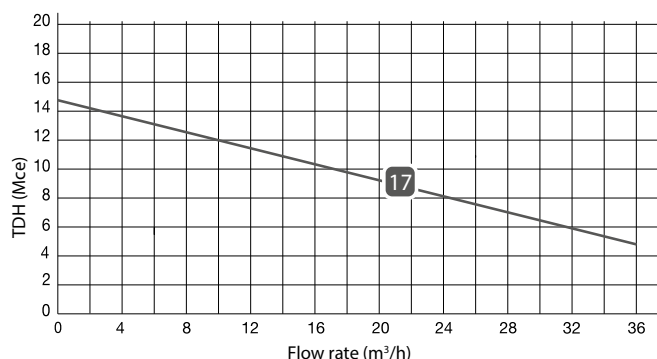

17 PJS0590M or T

SEMISOM 590
M or T

The box and the probe



Piezo probe
(10-metre cable)



Technical features

- 230 Volt single-phase or 400 volt four-phase + neutral wiring.
- Automatic pump start depending on the tank level.
- Automatic reverse at each start.
- Sound and visual alarm on alarm float.
- Lockable disconnecter.
- Push-button Force Start function on pumps.
- On/Off indicator display per pump.
- Dry contact for alarm transfer.
- **Volume:**
278 L x 130 D x 378 H mm

For more info, see page 46

Options



Support-mounted aluminium screen basket ^A

OS535

For units 3 m and 3.5 m tall. With handling chain.
Width 245 mm x Depth 215 mm x Height 400 mm.
Weight 2.9 kg.



50 kg folding gallow



Conforming with machine directive 2006/42/EC. Declaration of conformity upon delivery. Suitability for use assessment to be performed for permanent installation

50 kg, galvanised steel folding gallow with hoist and galvanised steel gallow brace. The gallow is moveable and can be folded up for easy transport (weight 17 kg).

OS101



Guiding bar-mounted aluminium screen basket ^B with handling chain.

Width 280 mm x Depth 120 mm x Height 400 mm. Weight: 4.9 kg.

For units 4 m to 5 m tall **DS2001050A**

For units 5 m to 6 m tall **DS2001070A**



Cabinet with base for exterior installation

CP510

In polyester. Dimensions: 540 L x 520 H x 240 D mm + 580 mm base height
For installing a 1- or 2-pump electrical box

Cable extension kit including:

- 1 connection for 2 single-phase and triple-phase pumps and 1 alarm float,
- 1 connection for piezo probe. To be installed in a manhole or in the unit

Contact Us



Non-contractual texts, dimensions, photos and diagrams

RESIDENTIAL BLOCK



SRT10 2 pumps on foot brackets, Dn65 with valve chamber



IL
>2200 mm,
up to 5200 mm

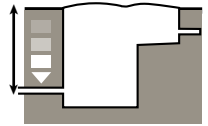

Product advantages

Easily serviced:
Direct access to the unit's valves and check valves via the manhole cover

Commissioning:
consult us

Design

- High mechanical resistance polyester, corrosion-proof tank and valve chamber,
 - Usable sub-inlet volume: 566 L,
 - Polyethylene baseplate for round cover
 - D740 polyethylene cover with quarter-turn opening/closure with security screw for the tanks and seal for the tank and valve chamber.
 - Ext. ø200 PVC pipe entrance – delivered with flexible adaptation sleeve
 - Ext. Ø75 PVC bonding pressure outlet pipe,
 - Female Ø 100/117 PVC sealing ventilation sleeve with stopper for exterior Ø 100 PVC pipe,
 - 2 Ø 76/90 TPC cable gland sheaths,
 - Lift loops.
 - Other dimensions upon request.
- Contact us.

Displayed model
PURP30P2DN065T

Interior equipment

> Tank-specific equipment:

- 2 submerged pumps,
- Cast-iron foot bracket system and stainless steel guiding bars (easier pump installation),
- 2 Dn65 PVC discharge pipes,
- 1 stainless steel brace (unit height. ≤ 3.5 m) for screen basket option,
- 1 alarm float (10-metre cable), and 1 piezo probe attached to chain with counterweight (10-metre cable),
- **Fall protection grill for the lifting well, safety guarantee during maintenance operations. Independent 304 stainless steel bars.**

> Chamber-specific equipment:

- 2 cast-iron adapter-fittings,
- 1 valve chamber/unit drip-return pipe,
- 2 PVC ball valves and 2 Dn65 cast-iron non-return ball valves attached on unions,
- 1 PVC U-bend connection.

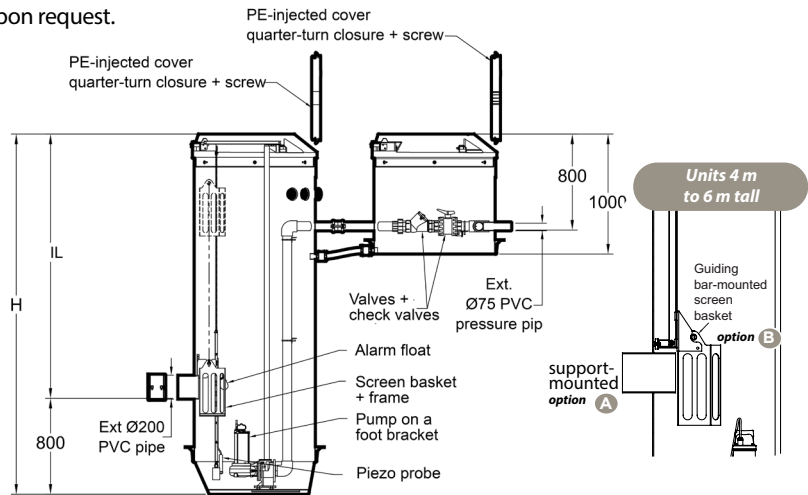
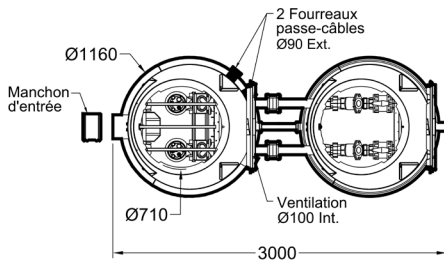

Non-contractual texts, dimensions, photos and diagrams

RESIDENTIAL BLOCK



For our SRT 10 models, selecting your pumping station is done in 3 steps:

1 Tank choice



2

Pump choice



3

Electrical box choice

Tank reference	H Height (mm)	Weight (kg)	(IL) (mm)	Ø Inlet (mm)	Ø Outlet (mm)
PURP30P2DN065T	3000	251	2200	Ext. Ø 200 PVC pipe	Ext. Ø75 PVC pressure pipe
PURP35P2DN065T	3500	269	2700		
PURP40P2DN065T	4000	286	3200		
PURP45P2DN065T	4500	304	3700		
PURP50P2DN065T	5000	322	4200		
PURP55P2DN065T	5500	340	4700		
PURP60P2DN065T	6000	358	5200		

Pump reference	Curve/pump No.	Flowarea (mm)	Amperage (amps)	Voltage (volts)	Power (kW)	Box reference
PJS0650T	03	65	4.6	Triple 400 V single	1.5	CSJ204
PJS0650HT	11	65	4.6			
PJS1000/50T	07	50	5.9			
PJS0650M	03	65	12	Single 230 V single	1.5	CSJ209
PJS0650HM	11	65	12			

Other Inlet Levels (IL) upon request: Contact our design office.

SRT10 + chamber Dn65



The box and the probe

Technical features

- 230 Volt single-phase or 400 volt four-phase + neutral wiring.
- Automatic pump start depending on the tank level.
- Automatic reverse at each start.
- Sound and visual alarm on alarm float.
- Lockable disconnector.
- Push-button Force Start function on pumps.
- On/Off indicator display per pump.
- Dry contact for alarm transfer.
- **Volume:**
278 L x 130 D x 378 H mm

Piezo probe (10-metre cable)



For more info, see page 46

Model selection

based on flow rate and Total Head (TDH). If you do not know which one to select, refer to page 45 to calculate the flow rate and TDH.

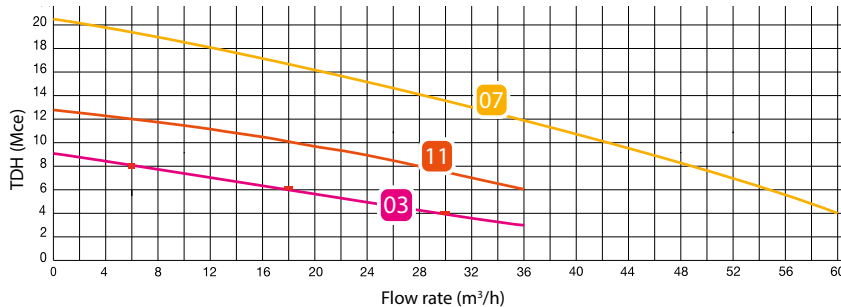

The pumps

230 V single-phase or 400 V triple-phase

Construction:

cast-iron pump housing and steel engine cover,

Temperature of liquids:

+50°C max.,

Protection: IP68, insulation class F,

Use: particle-laden liquid,

Discharge: 2" 1/2,

Equipped with a 10-metre cable and 2 wires for isotherm



SPECIFICALLY ADAPTED TO PUBLIC AREAS

NON-CLOGGING

Cast-iron Vortex wheel, Weight: 21 kg.

03 PJS0650M or T SEMISOM 650 M or T

11 PJS0650H M or T SEMISOM 650 H M or T



Cast-iron double-channel impeller, Weight: 39.4 kg.

07 PJS1000/50T SEMISOM 1000/50 T

Options



Support-mounted aluminium screen basket **A**

OS535

For units 3 m and 3.5 m tall. With handling chain. Width 245 mm x Depth 215 mm x Height 400 mm. Weight 2.9 kg.



50 kg folding gallow



Conforming with machine directive 2006/42/EC. Declaration of conformity upon delivery. Suitability for use assessment to be performed for permanent installation

50 kg, galvanised steel folding gallow with hoist and galvanised steel gallow brace. The gallow is moveable and can be folded up for easy transport (weight 17 kg).

OS101



Guiding bar-mounted aluminium screen basket **B**

with handling chain. Width 280 mm x Depth 120 mm x Height 400 mm. Weight: 4.9 kg.

For units 4 m to 5 m tall **DS2001050A**

For units 5 m to 6 m tall **DS2001070A**



Cabinet with base for exterior installation

CP510

In polyester. Dimensions: 540 L x 520 H x 240 D mm + 580 mm base height
For installing a 1- or 2-pump electrical box

Cable extension kit including:

- 1 connection for 2 single-phase and triple-phase pumps and 1 alarm float,
- 1 connection for piezo probe. To be installed in a manhole or in the unit

Contact Us



Non-contractual texts, dimensions, photos and diagrams

RESIDENTIAL BLOCK

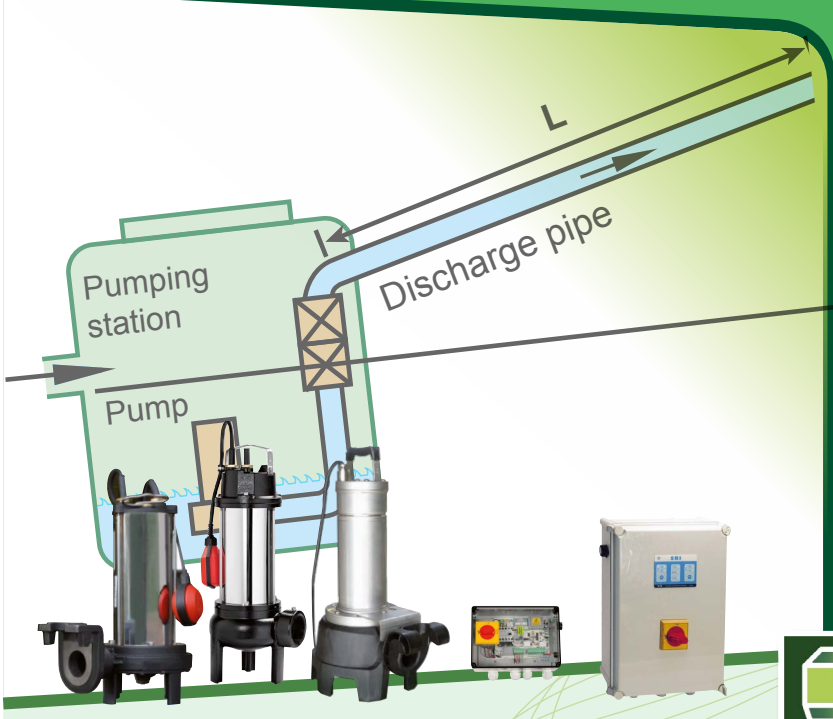

Lifting the technical guide

Pumping station assessment	_____	p.44
Calculation of Total Head (TDH)	_____	p.45
Electrical box for 2 pumps	_____	p.46
Electrical box for 1 pump	_____	p.47
<i>Installations:</i>		
Star 150, 700 and 710: exterior installation under landscaped areas	_____	p. 48
Star 900: exterior installation under concrete slabs	_____	p. 49
exterior installation under landscaped areas	_____	p. 49
Star 1000: exterior installation under landscaped areas	_____	p. 50
Star 1200R: exterior installation under landscaped areas	_____	p. 51
Srt 10m ancillary valve chamber: exterior installation under landscaped areas	_____	p. 52
Srt 10: exterior installation in hydromorphic ground	_____	p. 53
unit commissioning, maintenance operations	_____	p. 54-55
Standards and CE marking	_____	p. 56
Techneau equipment returns	_____	p. 57

Pumping station assessment

Installing a pumping station requires a specific technical assessment. We use the form to be filled out below, in addition to a computer programme that we've developed, to very quickly define the features of your future pumping station.

To respond precisely to your needs, please scan this page, fill it out and return it to us, by email to info@techneau.com and find this questionnaire online on our website www.techneau.com, under the "water pumping" page.

Date:

Project reference:

City/Town of the work site:

Will the pumping station be transferred back to a water treatment contractor?

yes no If yes, please note their contact information:

.....

Effluents: What is their nature?

*PE: Population Equivalent

Storm water	Flow rate =	m ³ /h
	Surface =	m ²

Waste water	Flow rate =	m ³ /h
	PE* =	

Spot heights (See diagram below):

Natural terrain **NT**: Outlet Level **OL**:

Inlet Level **IL**:

Dn1 of the connection to the station:

Discharge:

Length (linear metres) **L**:

Dn2 used inside:

Characteristics of pipes: PVC HDPE Cast-iron

Other:

Power supply: Triple 400 V Single 230 V single

Control box (Delivered with a 10-metre cable):

Its installation will be: inside outside

Distance between the box and the pumping station: metres

Pumping station:

Its installation will be: under a landscaped area under a roadway

Will it be followed by a valve chamber? Yes no

Study Call for tenders Project

Special technical specs provided? yes no

Private Apt. block

Basin Rainwater Collr.

Contact details

Company:

.....

First name:

.....

Last name:

.....

Address:

.....

.....

.....

.....

.....

.....

Postcode:

.....

City/Town:

.....

Tel.:

.....

Fax:

.....

Email:

.....

Terrain layout

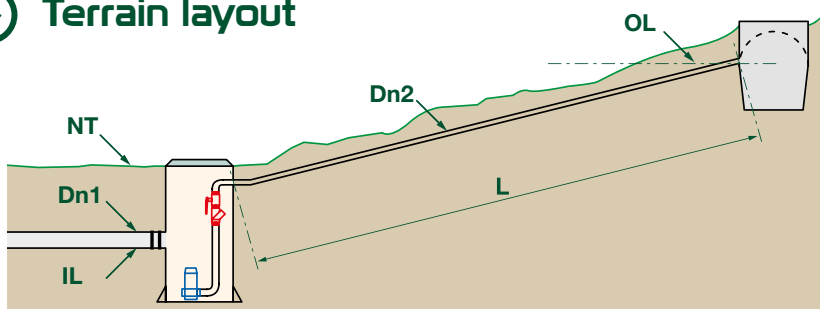

Context or comment:

Calculation of Total Head (TDH)

For each of our models, you can select from several types of pumps based on your permanent flow rate and the Total Head (TDH):

Calculate these figures and apply them to the pump graphs that correspond to your model.

➤ The installation's permanent flow rate (Qp) in m³/h

For waste water, this flow rate is calculated according to the number of users (Nb) on the basis of 150 litres per user per day.

The pump's flow rate is calculated through the formula: $Q_p = \frac{Nb \times 0.150 \times 3}{8} = \dots \text{ m}^3/\text{h}$

➤ Total Head (TDH)

This is the geometrical height that a liquid must be lifted (Hg) + the load losses in the discharge pipe (L).

1 • For a flow rate of 5 m³/h:

To ensure the self-cleaning (v + 0.7 m/s) in a 53/63 diameter pipe, we take into account a minimum flow rate of 5 m³/h.

Determination of the **TDH** with a 53/63 PVC pressure discharge pipe

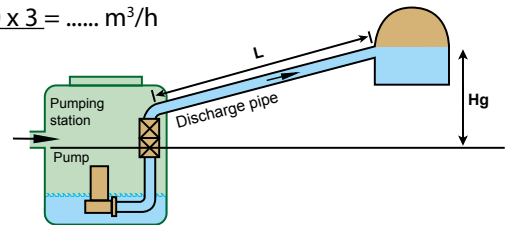

Geometrical height	Discharge length in metres											
	10	20	30	40	50	60	70	80	90	100	110	120
1	1.17	1.34	1.51	1.68	1.85	2.02	2.19	2.36	2.53	2.7	2.87	3.04
2	2.17	2.34	2.51	2.68	2.85	3.02	3.19	3.36	3.53	3.7	3.87	4.04
3	3.17	3.34	3.51	3.68	3.85	4.02	4.19	4.36	4.53	4.7	4.87	5.04
4	4.17	4.34	4.51	4.68	4.85	5.02	5.19	5.36	5.53	5.7	5.87	6.04
5	5.17	5.34	5.51	5.68	5.85	6.02	6.19	6.36	6.53	6.7	6.87	7.04
6	6.17	6.34	6.51	6.68	6.85	7.02	7.19	7.36	7.53	7.7	7.87	8.04
7	7.17	7.34	7.51	7.68	7.85	8.02	8.19	8.36	8.53	8.7	8.87	9.04
8	8.17	8.34	8.51	8.68	8.85	9.02	9.19	9.36	9.53	9.7	9.87	10.04

2 • For a flow rate of 10 m³/h:

To ensure self-cleaning (v + 0.7 m/s) in a 63/75 diameter pipe, we take into account a minimum flow rate of 10 m³/h.

Determination of the **TDH** with a 63/75 PVC pressure discharge pipe

Geometrical height	Discharge length in metres											
	10	20	30	40	50	60	70	80	90	100	110	120
1	1.15	1.3	1.45	1.6	1.75	1.9	2.05	2.2	2.35	2.5	2.65	3.8
2	2.15	2.3	2.45	2.6	2.75	2.9	3.05	3.2	3.35	3.5	3.65	4.8
3	3.15	3.3	3.45	3.6	3.75	3.9	4.05	4.2	4.35	4.5	4.65	5.8
4	4.15	4.3	4.45	4.6	4.75	4.9	5.05	5.2	5.35	5.5	5.65	6.8
5	5.15	5.3	5.45	5.6	5.75	5.9	6.05	6.2	6.35	6.5	6.65	7.8
6	6.15	6.3	6.45	6.6	6.75	6.9	7.05	7.2	7.35	7.5	7.65	8.8
7	7.15	7.3	7.45	7.6	7.75	7.9	8.05	8.2	8.35	8.5	8.65	9.8
8	8.15	8.3	8.45	8.6	8.75	8.9	9.05	9.2	9.35	9.5	9.65	10.8

Example: **Flow rate and TDH** calculations for **20** people with a geometrical lifting height of **4** m and a discharge length of **70** m, **53/63 PVC** discharge pipe.

Flow rate (Qp) = $\frac{20 \times 0.150 \times 3}{8} = 1.125 \text{ m}^3/\text{h}$

We then judge a minimum flow rate to be 5 m³/h (self-cleaning).

TDH (see table above) = 5.19 m.

Therefore, the pump should provide a flow rate of 5 m³/h at 5.19 m. **Select pump no. 9.**

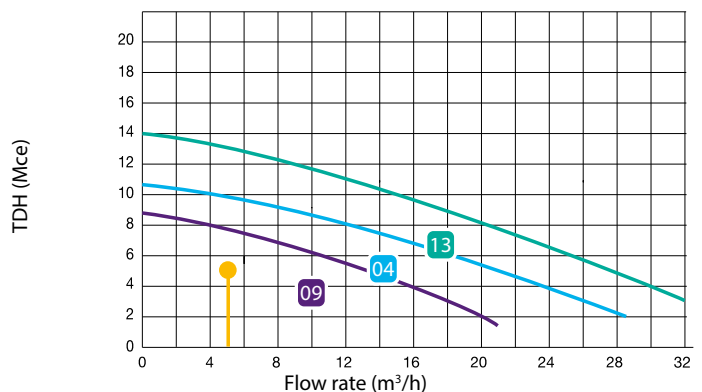

Protection and control box for 2 pumps



SRI box

- The pressure probe manages the levels. The stainless steel piezo probe is either installed in a sheath or attached to a chain with a counterweight. It provides instant, precise effluent measurements. Its resilience and durability are why it's so widely used in sanitation.
- The electrical box protects the pumps from overcurrents.
- For pumps outfitted with isotherms, the box also protects the pumps from overheating.

Technical features

- 230 Volt single-phase, 400 volts + neutral mode.
- Automatic pump starts depending on the tank level.
- Automatic reverse at each start.
- Sound and visual alarm on alarm float.
- Lockable disconnecter.
- Push-button Force Start function on pumps.
- On/Off indicator display per pump.
- Dry contact for alarm transfer.
- **Dimensions: 300 L x 140 D x 378 H mm**



Operation

- Connected to an alarm float, the electrical box alerts the operator of overflow risks in case of any overloading or discharge failures.
- In case of pressure measurement system failures, the regulator takes over and manages the degraded operating mode. The electrical box displays the anomaly: "Sensor failure".

References selection:

230 V single	400 V four-phase + neutral mode
<i>dual-voltage from 1.6 to 2.5 A: CSJ201</i>	
<i>dual-voltage from 2.6 to 4.0 A: CSJ202</i>	
<i>dual-voltage from 4.1 to 6.3 A: CSJ204</i>	
<i>dual-voltage from 6.4 to 10.5 A: CSJ206</i>	
<i>from 9 to 12 A (with capacitors integrated into the electrical box): CSJ209</i>	-

 **Interior installation** only.

OUR
ADVICE

“A protective cabinet is necessary for exterior installation. It will provide greater security to your electrical system.”

Cabinet with base for exterior installation

In polyester. Dimensions: 540 L x 520 H x 240 D m
+ 580 mm base height. Compatible 1- or 2-pump electrical box
Equipped with an earthing terminal

CP510



Important

Our electrical boxes are coupled to a power supply equipped with a protective, two-pole or four-pole sectioning device depending on the circumstances, in compliance with the EN 60204 standard.

CP03 and CP04 electrical box

Use

- **Alarm and control box** for single-phase pump with integrated float, 5 A max. (optional RB10). It protects the pumps from overcurrents.

Technical features

- 230 V single-phase pump with integrated float.
CP03 5A max.
CP04 10A max.
- IP54 watertightness,
- Pump operation display,
- Indicator light provides information on pump inactivity of more than 24 hrs. and resets at the first start-up.
- Information on the pump's abnormally long operating time: indicator light + sound alarm
- Anti-overflow protection: indicator light + sound alarm. Install a RB10 alarm float (not included).
- Alarm transfer.



Operation

Electrical box details

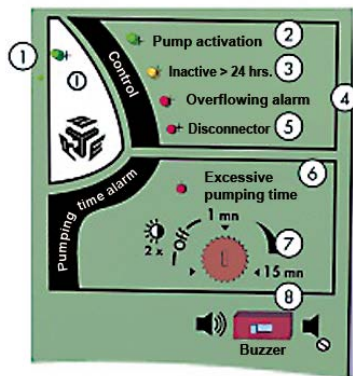

- 1 Voltage presence indicator light,
- 2 Pump activation indicator light,
- 3 +24 hrs. inactivity indicator light,
- 4 Overflow alarm indicator light (if alarm float is connected),
- 5 Overload shutoff indicator light.
- 6 Excessive pumping time indicator light.
- 7 Adjustment for the pump's maximum operating time before alarm.
- 8 Sound alarm switchover/muting.



Important

Our boxes are coupled to a power supply equipped with a protection and two-pole or three-pole sectioning device depending on the circumstances, in compliance with the EN 60204 standard.

STAR150 700 and 710

Outside installation under landscaped areas and hydromorphic ground

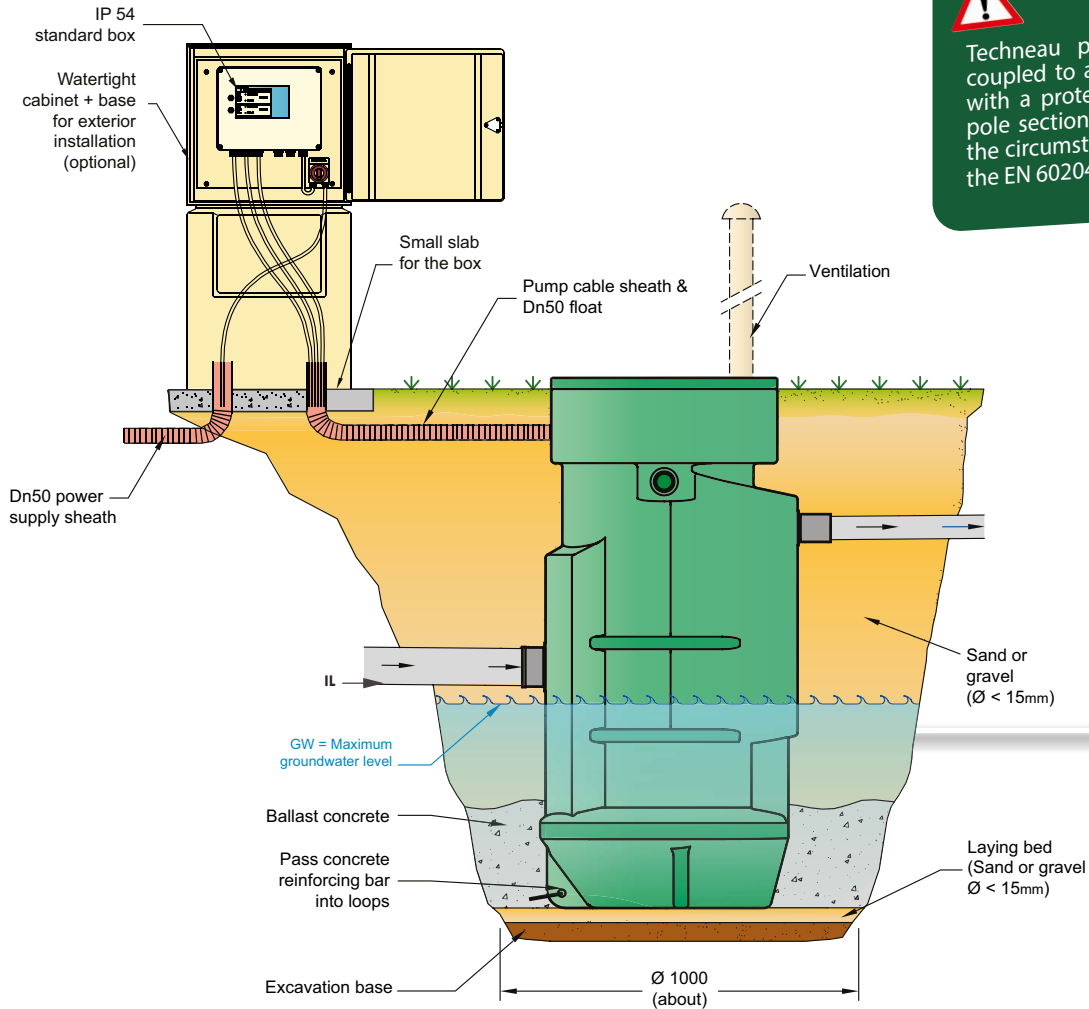

Important, box installation

⚠ Techneau pump control boxes are coupled to a power supply equipped with a protective, two-pole or three-pole sectioning device depending on the circumstances, in compliance with the EN 60204 standard.

- The standard box must be installed in a place where it cannot be affected by bad weather. The cabinet + base (option ref. CP510) can be installed outside.
- Provide earthing in addition to the electrical protection and sectioning device.
- A single extension (H 400 mm) is possible on Star 700 and 710.

- Extension impossible if there is groundwater.
- **Maximum groundwater levels:**

	STAR 150	STAR 700	STAR 710
No extension	GW* ≤ standard IL*		
Extension used	The tank cannot be in contact with groundwater		

*GW: maximum ground level (Groundwater or run-off water).
IL: Inlet Level.

The manual delivered with the unit is the only authoritative document.
For any other installation configurations, contact us.

STAR900 Outside installation under a concrete slab and hydromorphic ground

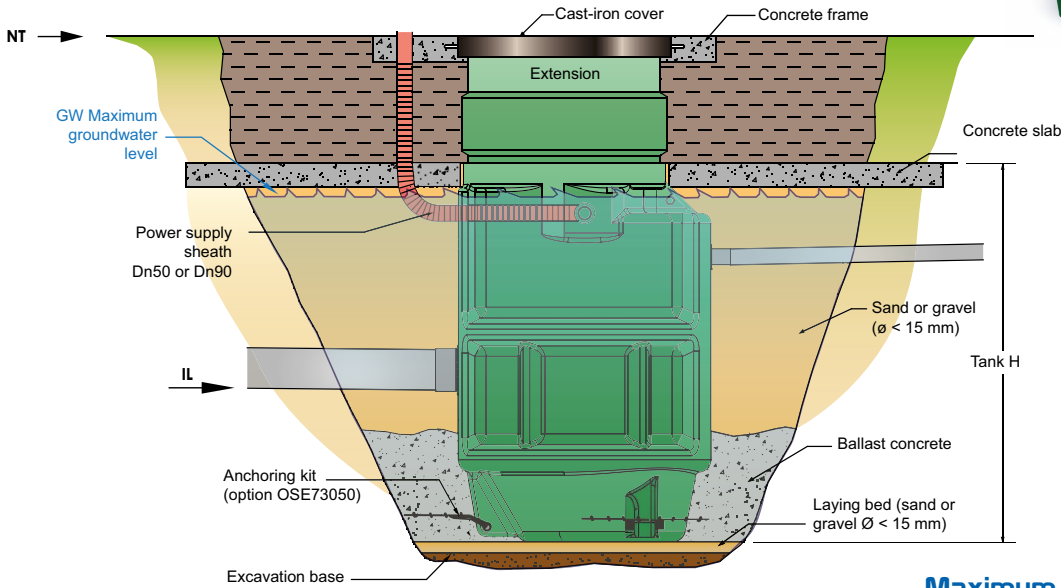

Important points

- The Star 900 units can be used with 1 extension maximum. Extensions are either telescopic or fixed according to the tank models:
 - ref. ETR041 or ETR060 for STAR 900.
- In case of installation below a roadway, a protective slab must be used for backfilling vertical loads.
- Vertical loads (covers, frames, slabs) must not be applied in any situation whatsoever on the tank or polyethylene extension.
- The concrete slabs must be sized by taking into account different factors (backfilling height, vehicle traffic).

Maximum groundwater

With or without an extension, it depends on the installation configuration and the tank model.

Configuration	STAR900
Extension used	GW* ≤ Tank H
No extension	GW* ≤ NT

*NT: Natural terrain/IL: Inlet Level/GW: maximum ground level (Groundwater or run-off water)/tank height extends past extension

STAR900 Exterior installation under landscaped areas

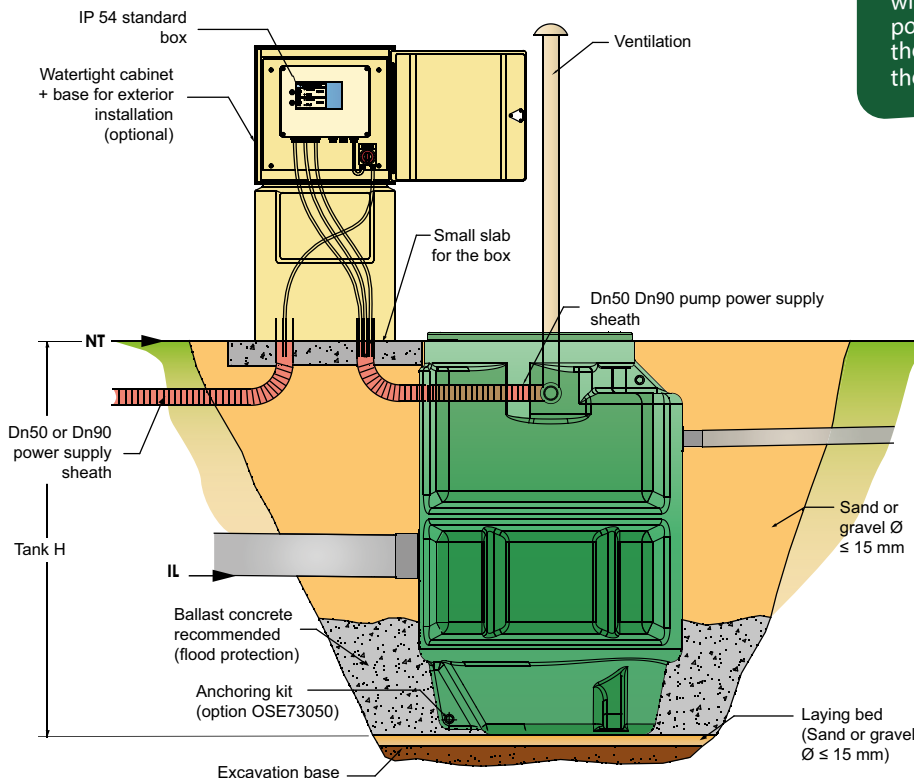

Important, box installation

⚠ Techneau pump control boxes are coupled to a power supply equipped with a protective, two-pole or three-pole sectioning device depending on the circumstances, in compliance with the EN 60204 standard.

The manual delivered with the unit is the only authoritative document.
For any other installation configurations, contact us.

STAR1000 Exterior installation under landscaped areas



Operating layout diagram,
STAR 1000 base Height 2 m

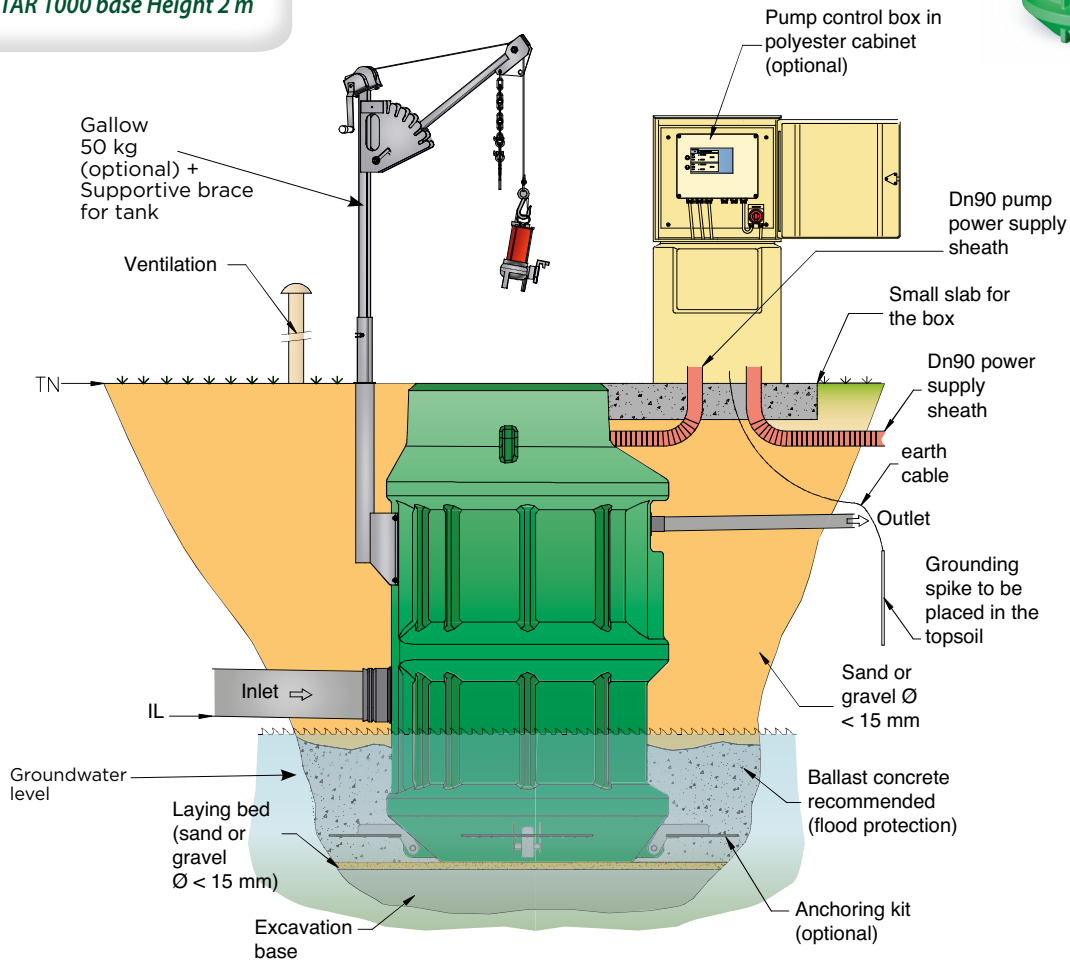

Important points

- > The Star 900 units can be used with 1 extension maximum per access point. The extensions are either telescopic or fixed according to the tank models: • ref. RE207 or TCRE207.
- > In case of installation below a roadway, a protective slab must be used for backfilling vertical loads.
- > Vertical loads (covers, frames, slabs) must not be applied in any case on the tank or polyethylene extension.
- > The concrete slabs must be sized by taking into account different factors (backfilling height, vehicle traffic).

> Maximum groundwater

With or without an extension, it depends on the installation configuration and the tank model.

Configuration	STAR1000
Extension used	$GW^* \leq IL^*$
No extension	$GW \leq NT$

*NT: Natural terrain/IL: Inlet Level/GW: maximum ground level (groundwater or run-off water)/tank height



Important

Our boxes are coupled to a power supply equipped with a protective, two-pole or three-pole sectioning device depending on the circumstances, in compliance with the EN 60204 standard.

The manual delivered with the unit is the only authoritative document.
For any other installation configurations, contact us.

STAR1200R Exterior installation under landscaped area

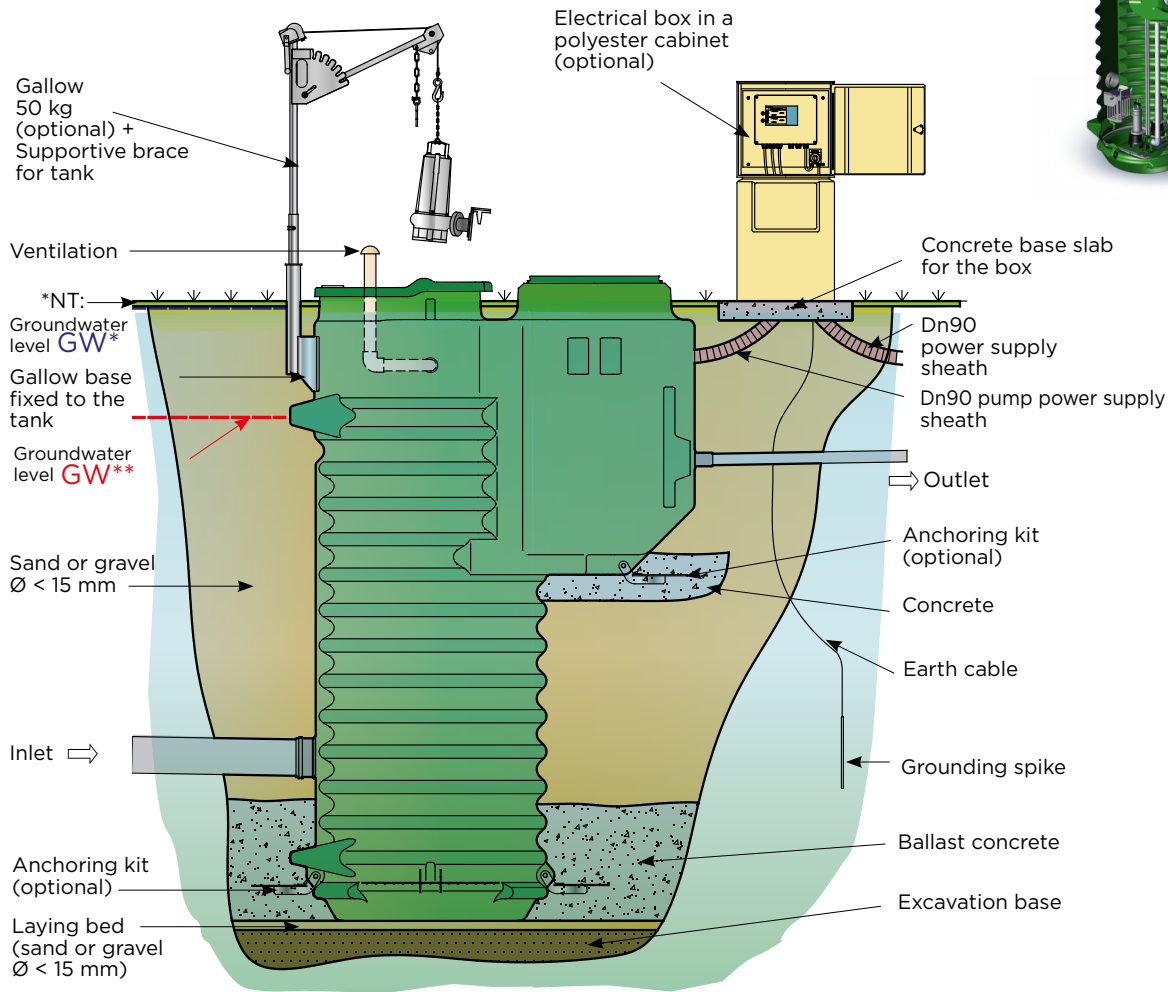
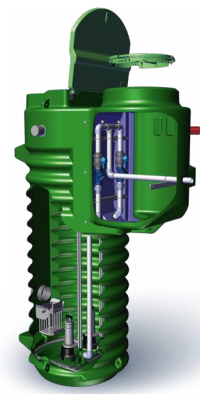

- Perform excavation based on the tank dimensions.
- Place the grounding spike in the topsoil.
- Place the unit on a 100 mm laying bed (sand or gravel $\varnothing < 15$ mm).
- Set up the anchoring kit for the tank and the valve chamber (optional).
- Stabilise the tank by adding 100 to 200 litres of clean water to it.
- Pour the ballast concrete (poorly draining soil or a risk of rising groundwater requires that the unit be ballasted).
- Note: depending on the amount of concrete used, it may be necessary to put clean water into the unit.
- Continue gradually by balancing the interior water level and the exterior concrete level.
- Connect the pipes and add 10/15 gravel backfilling up to the base of the valve chamber.
- Pour somewhat watery concrete at the base of the valve chamber.
- Finish by applying 10/15 gravel backfilling.
- Install a protective device for the electrical power supply.



Important

Our boxes are coupled to a power supply equipped with a protective, two-pole or three-pole sectioning device depending on the circumstances, in compliance with the EN 60204 standard.

Groundwater level:

	Unit H	GW
* CB1225/30/35/40	Up to 4 m	GW = NT
** CB1245	4.5 m	GW = (MT - 500 mm)

The manual delivered with the unit is the only authoritative document.
For any other installation configurations, contact us.

SRT10 Exterior installation under landscaped area

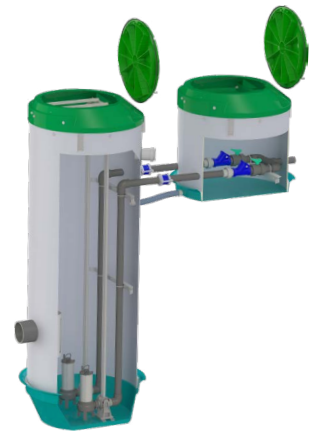

Operating layout diagram, SRT 10 base with ancillary valve chamber

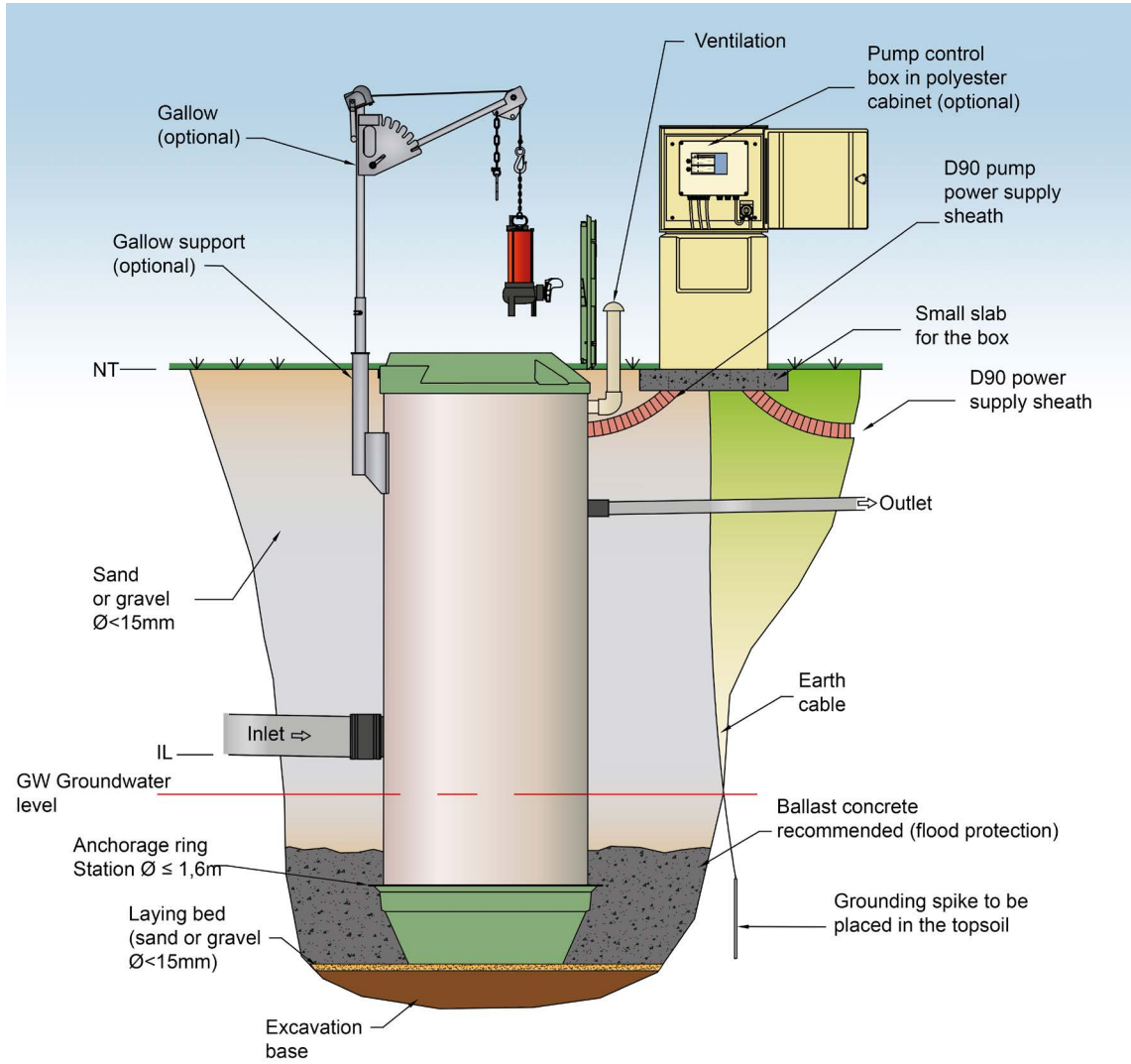

- Perform excavation based on the tank and valve chamber dimensions. Insert the grounding spike. Place a 30 mm laying bed (sand or gravel $\text{Ø} < 15 \text{ mm}$) around the tank and valve chamber. Place the unit and valve chamber on their respective laying beds.
- Pour ballast concrete, a protective measure in case of flooding (strongly recommended).
- Connect the pipes and add 10/15 gravel backfilling.
- Install a protective device for the electrical power supply.

⚠ Important

Our boxes are coupled to a power supply equipped with a protective, two-pole or three-pole sectioning device depending on the circumstances, in compliance with the EN 60204 standard.

The manual delivered with the unit is the only authoritative document. For any other installation configurations, contact us.

SRT10 Outside installation under landscaped areas and hydromorphic ground

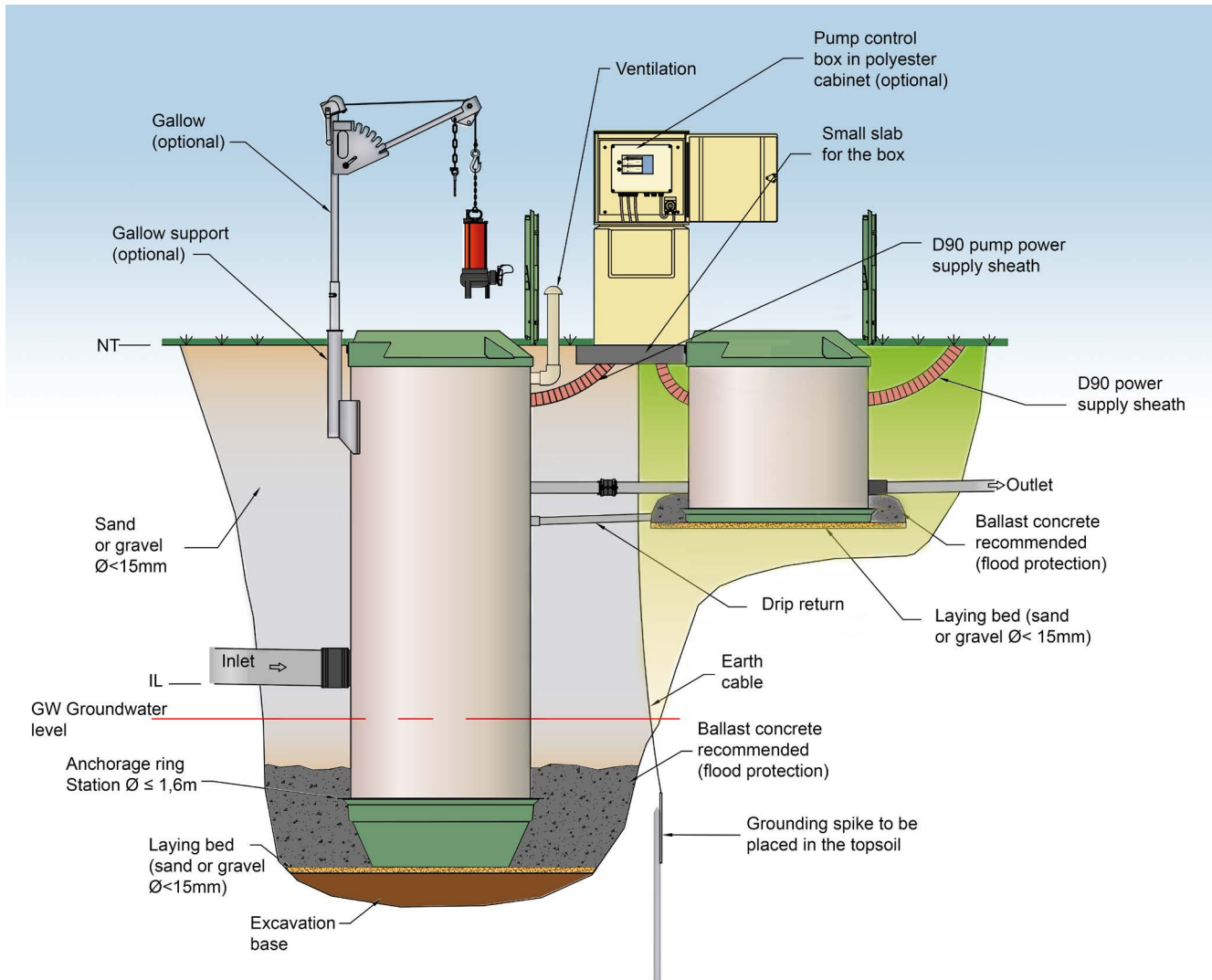

- Perform excavation based on the tank dimensions. Insert the grounding spike.
Place down a 30 mm laying bed (sand or gravel $\varnothing < 15\text{mm}$)
Place the unit on the laying bed.
- At the same time, gradually pour in the ballast concrete and balance it off by adding water to the tank.
- Connect the pipes and add 10/15 gravel backfilling.
- Install a protective device for the electrical power supply.



Important

Our boxes are coupled to a power supply equipped with a protective, two-pole or three-pole sectioning device depending on the circumstances, in compliance with the EN 60204 standard.

The manual delivered with the unit is the only authoritative document.
For any other installation configurations, contact us.

Pumping unit commissioning

As a reminder, our pumping stations, except for the Star 1000, Star 1200R and PUP, are delivered with the regulation system and with the pumps already connected to the control box. If those installing the pumping stations wish, we offer on-site commissioning assistance.



Operations under Techneau's responsibility: (When commissioning assistance is requested)

- 1 • Connection of electrical cable coming from the EDF box to our control box,
- 2 • Connection and verification of the pumps' rotating direction,
- 3 • Set up of the pumps on the foot brackets and attachment of the cables,
- 4 • Connection of the level regulators and/or probe to the control box (depending on the model),
- 5 • Verification of the unit's proper work order upon installation,
- 6 • Water tests.

Operations under the responsibility of the company:

- 1 • Placement of the pumping station and connection to the different pipes,
- 2 • Install a Dn90 sheath between the EDF box and the Techneau control box,
Do not forget to run the mains power cable,
This cable must run and connection to the control box.
- 3 • Also Install 2 Dn90 sheaths between the unit and the Techneau control box for running cables from the pumps, level regulators and/or probe.
- 4 • Installation of the EDF mains supply box, differential circuit breaker and the disconnecter if the case may be,
- 5 • Emptying and cleaning of the pumping station and the upstream network before unit commissioning,
- 6 • Provision of hoisting equipment suitable for handling the pumps on the day the pumping station is put into service,
- 7 • Inspection by an approved body of the electrical installation and a Consuel request for switching on the EDF power supply (if the metering is independent from that of the establishment),
Note: TECHNEAU can provide the subcontracting services for this inspection and Consuel request.
- 8 • Functional tests performed later on after the initial commissioning.

Some recommendations

- Be sure to measure the length of your sheaths before burying them.
- If a screen basket is installed, the covers have to be easy to move: Avoid using heavy cast-iron covers that the maintenance technician would have difficulty handling.
- To make maintenance and servicing easier, the pumps' control box must be as close as possible to the pumping station.
- If using long cables, install a pull box at least every 40 m.
- If using a piezo probe longer than 10 m, install a CAPIBOX junction box.
- Concrete reducing heads are not allowed.

A pumping station and its equipment undergo operational stress every day and it is constantly inundated with aggressive liquids (e.g., waste water) and substances that cause clogging (e.g., oils and grease).

Regular preventive maintenance prevents early component wear that leads to malfunctions. It also increases the lifespan of your pumping station.

How often the unit is serviced depends on the type of the water running through it. However, we recommend servicing it 3 to 4 times per year.

To do this, our technicians in the field who are specially trained to inspect and service your pumping equipment are available to assist you throughout mainland France.

Our telephone support team (tel.: +33 (0)2 33 77 21 19) is also ready to answer all of your questions. You can also contact us by email at: maintenance@techneau.fr

Techneau offers different kinds of preventive maintenance contracts, established with you according to your needs or those of your operator.

The pumps, pumping station and its internal equipment, the pump regulation system and the control box can be tested and verified to prevent any inconvenient malfunctions.

➤ Maintenance provided at each inspection in 10 steps:

- 1 • Cut the power supply,
- 2 • *Model with floats:*
 - Take out the tank floats, clean them properly and remove sediment clinging to the floats.
- 2^a • *Piezo model (SRI):*
 - Take out the probe, remove the cap if there's any clogging, clean with a cloth.
 - Do not apply pressure or use a tool that can damage the membrane.
 - Put the probe back and verify that it's adjusted correctly.
- 3 • Remove large collections of grease floating on the surface.
- 4 • Turn the pump back on manually or through a forced start and have it discharge liquid until it is unprimed to empty the tank as much as possible.
- 5 • Use a large amount of water to flush out the inside walls of the tank as well as the pipes and accessories in contact with the effluent. Make sure the pump is properly re-primed.
- 6 • Verify the control box's automation sequences.
- 7 • *2 times per year:*
 - Take the pumps out and, using a large amount of water, flush out the suction housing of each pump.
 - Verify the condition of the wheels as well as the quality of the oil if the pumps have an oil reservoir (see the manufacturer's manual),
 - Put the pumps back in place, fill up the unit with clean water, and run the pumps to verify the amperage.
 - Have an authorised body verify the components of the electrical system.
- 8 • *1 time per year:*
 - The pumping station should be completely drained and flushed out with a large amount of water.
- 9 • Presence of a screen basket:
 - The cleaning frequency of the screen basket must be adapted to the amount of waste.
 - We recommend to have it cleaned at least every 2 weeks.
- 10 • We recommend that you take out a maintenance contract with a specialised company.

The manual delivered with the unit is the only authoritative document.

Pumping tests and certification



Testing basis: verification of a pumping station's performance

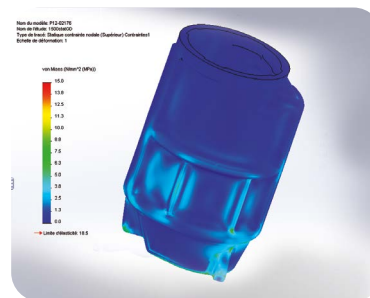

Tests, certification and product tests:

Our company has ISO 9001 certification.

All of our products are tested before going to market. Our design office and our testing facilities integrated into our factory enable to guarantee you that Techneau products comply with the standards in force.

Adapted training:

Our centre based in Marigny offers you the chance to receive the most advanced training for:

- the full range of our products, their performance and features.
- their use and the rules to be followed in their implementation,
- additional information on the market, sales as well as regulations in force.

Training at Techneau or how to respond completely to the needs and expectations of the customers.



Date: 25/08/2022

	Return no. = original order no. <i>To always be attached, otherwise form will be rejected</i>
Customer	
Contact	

Equipment concerned:

Reason for return:

Return logistics:

- **Handled on your own:**
- **Handled by Techneau:**

Possible removal date: _____

Removal address:

Terms of return:

Initial value (A)	€ excluding tax
<i>Cost of initial delivery (B)</i>	€ excluding tax
<i>Cost of return transport (C)</i>	€ excluding tax
<i>Discount* on equipment (D)</i>	€ excluding tax
Total amount of return <i>(A - (B+C+D))</i>	€ excluding tax

 *The discount amount may be reviewed after a complete inspection of the equipment upon receipt at our workshops.

Customer approval for the return:

First name – Last name – position

Agency stamp



Custom manufacturing possible for pumping stations up to 2.9 m in diameter

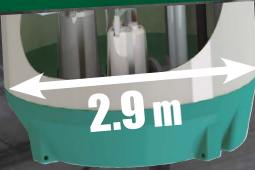

Is also

WATER ENGINEERING

- **Water treatment**
Hydrocarbon separators
Grease/starch separators
Settling tanks
- **Hydraulic equipment**
Flow regulators
VORTEX flow controller
Penstocks
End check valves

GROUND EQUIPMENT

- **Manhole covers**
- **Stainless steel gutters & Siphons**

Tel.: +33 (0)2 33 77 58 05
e-mail: eqs@techneau.com



Pumping catalogue
September 2022
edition

Your distributor:

Z.A La Chevalerie
50570 MARIGNY-LE-LOZON
Tel.: +33(0)2 33 56 62 08

Email: info@techneau.com

www.techneau.com

Techneau, a company of the group



Ref. 92901. Non-contractual photos. In an effort to constantly improve its products, Techneau reserves the right to change the dimensional characteristics of its products without warning.